

**MANUAL  
HYDRAULIC BUFFER  
Model HD 2.0**



## **GENERAL INFORMATION**

This manual provides information on installation, maintenance and field repair for ENIDINE GmbH HD Shock Absorbers.

In order to select the hydraulic buffer that best suits your operation, it is important to follow the certified safety standards specified; the selection guidelines provided by ENIDINE and specifics of your particular application.

For the bladder type (standard) version, the environment temperature on shock absorber outer cylinder must not exceed 60°C, the temperature of the cylinder must not exceed 70°C during operation. In seldom cases a delay in the return of the piston rod can occur at units resting in a compressed position for long time (Longtime Parking Position). In such cases we recommend to push the rod in the compressed position a few millimetres insuring a proper return.

**Shock Absorbers for emergency application:** In this conditions it is assumed that the shock absorber is not stroked during normal operations. For safety reasons the shock absorber should be checked for functionality (see section “Maintenance instruction”) at least every 12 months

**Shock absorber used for normal operation:**

These units should be checked visually (piston rod surface; leakage) and functional (see section “Maintenance instruction” ) every 6 month.

Based on the cycle rate, in general after 250.000 cycles, a replacement of wearing parts could be required. In general the replacement or an overhaul of the shock absorber is recommended after at least 8 years.

ENIDINE makes no express or implied warranties of any kind as to the material contained in the guide. There is specifically no implied warranty of merchantability or fitness for any particular purpose.

ENIDINE shall not be responsible for damages (direct, indirect or consequential) and assumes no liability should the guide produce results other than those intended or for the failure of any ENIDINE products due to the misapplication caused by the use of the guide.

A properly sized and installed Shock Absorber will perform as expected. If there is anything unique about your application, contact ENIDINE for assistance.

We know of no other large-bore shock absorber that can withstand the harsh environments and life-cycling as the ENIDINE design.

## MAINTENANCE INSTRUCTIONS

It is recommended that preventive maintenance program be established to obtain the maximum life from the shock absorber.

A routine inspection should be performed every 6-12 months and this inspection should include the following:

- 1 Stroke in the piston rod completely to check the shock absorber (see "Filling Pos.14). Then release the piston rod, it should return to its fully extended position. Should the piston rod not return to the fully extended position, then check the air pressure in the bladder. Information regarding bladder pressure and oil volume is indicated on the label at the shock absorber as illustrated below. The needed air port adapter is located in the front side of the bearing covered with a plastic cap.
- 2 A visual inspection of the piston rod sealing concerning leakage should be performed.
- 3 Please contact ENIDINE or your closest ENIDINE representative in case the piston rod does not return completely in spite of the checks done as per item 1, or if a leakage occurred.

The standard shock absorber bladder is pressurised with 3.5 bar air with the piston rod fully extended. The maximum recommended air pressure (with rod extended) is 5.0 bar. The increase to 5.0 bar, under standard conditions, increases the rod return force.

Information regarding bladder pressure and oil volume is indicated on the I.D. label at the shock absorber as illustrated:

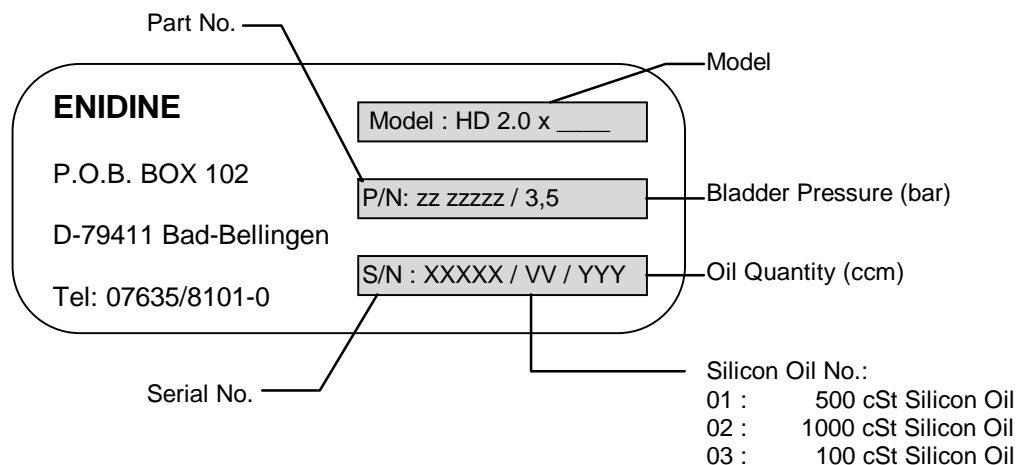

## **FIELD REPAIR-INSRUCTIONS HD 2.0** **DISASSEMBLY**

- 1 **(Valid for HDA Version only)**  
Insure that the adjustment screw is totally open during the filling respectively depressurisation of the unit.
- 2 **(Valid for Bladder Version only)**  
Remove protective cap (36) to access charging valve.  
**CAUTION:**  
**DEPRESSURIZE THE SHOCKABSORBER COMPLETELY BEFORE YOU START DISASSEMBLY.**
- 3 **(Valid for Bellow Version only)**  
Remove the bellow by loosen hose band on the piston cap and on the bearing.
- 4 **(Valid for Spring Version only)**
  - 4.1 Press the spring down towards the bearing and remove cap screw (25) and piston cap (14).  
**CAUTION:**  
**TAKE CARE THAT THE ROD WILL NOT BE DAMAGED BY CLAMPING WITH A VICE OR A WRENCH.**
  - 4.2 Uncompress the spring slowly and remove the spring.  
**CAUTION:**  
**A RAPIDLY UNLOADED SPRING CAN OCCURE BADLY INJURED.**
- 5 Pull the rod (13) out to its max. extended position. Remove fillplug (28) resp. sensor housing (70) [at HD with sensor] and drain oil from the damper into a collecting tank.
- 6 Remove cap screw (25) and remove piston cap (14).  
**CAUTION:**  
**TAKE CARE THAT THE ROD WILL NOT BE DAMAGED BY CLAMPING WITH A VICE OR A WRENCH.**
- 7 Loosen the 2 flange locating screws (40) at the flange (6) and the flange SHS screw (39).
- 8 Unscrew (counterclockwise) and remove lockring (5) .
- 9 Turn bearing (2) counterclockwise to detach from innertube (3) and pull bearing (2), together with the piston rod/ piston head assembly (13, 8) out of shockabsorber.
- 10 Slide bearing assembly (2) off of the piston rod/ piston head assembly (13,8).

- 11 Remove the outer cylinder (4) from cylinder base (1).
- 12 Remove the rod seal (20) and the rod wiper (21) out of the bearing (2) preventing nicking and scratching to the seal grooves.
- 13 To remove the bladder accumulator (15) from the outer cylinder (4) remove jam nut (15/2) at the valve unit without turning the bladder. Press the valve stem through the port plug (10) to the inner side.  
**CAUTION:**  
**TEST THE BLADDER ACCUMULATOR FOR AIRTIGHTNESS (TEST PRESSURE SHOULD NOT BE GREATER THAN 0,1 BAR) BEFORE YOU USE IT FOR ASSEMBLY.**
- 14 Drain remaining oil from the cylinder and clean all parts thoroughly. Inspect components for any unusual or excessive wear and replace as required.

## **FIELD REPAIR-INSTRUCTIONS HD 2.0** **ASSEMBLY**

- 1 Make sure that all parts have been thoroughly cleaned and replace all seals and worn or damaged parts.
- 2 In the case that the charge port plug (10) was removed at disassembly, apply Loctite #270 to the thread and install into cylindertube (4) together with the copperwasher (38). Torque to 50 Nm.
- 3 If a new accumulator bladder is used, remove the valve cap (15/1), the hex nut (15/2) from the valve body. Place the O-Ring (27) over the valve body and push down against the remaining hex nut (15/3). Apply silicon sealant to the O-Ring.
- 4 Roll up the bladder (15) and install into cylinder tube (4). Push valve housing through charge port plug (10). Make sure that the bladder is placed against the cylinder wall. While keeping the bladder and valve housing from turning or twisting, install and tighten the hex nut (15/2).
- 5 If the piston (7) needs to be replaced, remove retaining ring (23) and mount the new piston (7) with new piston ring (24) on the piston head (8). Use a new retaining ring (23).
- 6 If the piston head (8) was disassembled from the piston rod (13) , then attach the piston head to the piston rod and secure with SHC screw (12), Loctite #270 and a torque level of 50 Nm.
- 7 In case the shock tube (3) was detached from the cylinder base (1), apply Loctite #270 to the thread. Securely tighten the parts.
- 8 Place the cylinder base assembly upright and place it (if available) into a floor base assy which protects the cylinder base from turning or twisting. Depending on the mounting style add the spacer (42) or mounting flange (6) to the cylinder base (1).
- 9 After applying a coating of Vaseline on the O-Ring (16) install it into the cylinder base.
- 10 Orient cylinder/bladder assembly to the shock tube and carefully put this assembly over the shock tube.
- 11 Make an identifying mark on the outer cylinder (4) and cylinder base (1) to detect any radial motion between these parts during final assembly.
- 12 Insert the piston rod/-head assembly (13,8,...) into the shock tube.

- 13 Fill the assembly with the required volume and type of oil. Consult identification label or ENIDINE GmbH for the correct oil specification.
- 14 Slide bearing assembly (2) onto the piston rod (13). Push toward the shock tube (3), screw it into the shock tube and tighten firmly.
- 15 Depending on the mounting style place the flange (6) or the spacer (42) over the bearing assembly (2).
- 16 Install the lock ring (5) on the bearing (2).
- 17 If a flange (6) is installed, orient this with the pilot holes to the cylinder holes. Install set screws (39,40) using silicon sealant. Then only snug the set screws (at this point the lock ring is not tightened).
- 18 Firmly tighten the lock ring (5) and the set screws (39,40).
- 19 Finally install the piston cap (14) with the SHC screw (25) to the piston rod. Use Loctite #270 and torque level of 50 Nm.

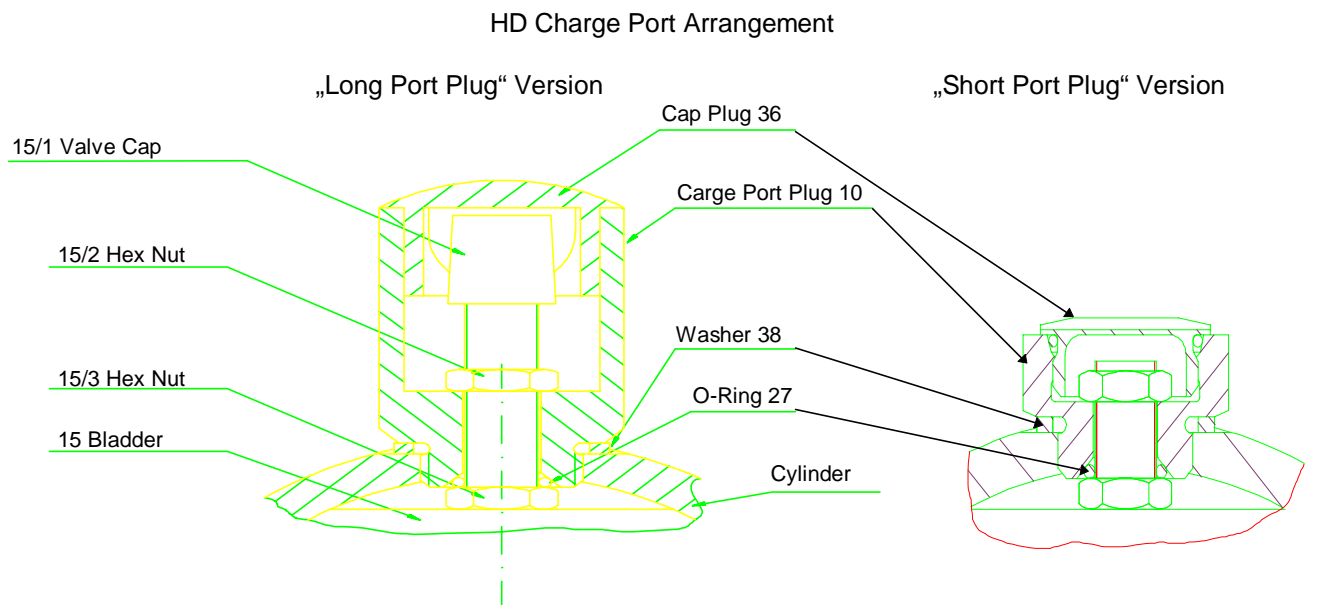

## **FIELD REPAIR-INSTRUCTIONS HD 2.0** **FILLING**

**NOTE: If the I.D. label (32) shows no special oil No. next to the oil volume, the shock absorber is filled at ENIDINE with a hydraulic fluid named ARAL AWS 46.**

- 1 Place the depressurised shock absorber (resp. return spring not mounted) with the compressed piston rod (13) and fill plug (28) resp. sensor housing (70) [at HD with sensor] up in horizontal position. Place the fill plug (28) resp. sensor housing (70) [at HD with sensor] 20-30 mm higher than the shock absorber end.
- 2 Remove the fill plug (28) resp. sensor housing (70) [at HD with sensor] and install a filling reservoir (plastic funnel) into the fill port.

**CAUTION:**

**VOLUME OF THE FILLING RESERVOIR SHOULD BE TWICE THE VOLUME OF THE PISTON ROD.**

- 3 **(Valid for Bladder Version only)**  
Remove the protective caps (36, 15/1) on the port plug (10) and the valve body. Apply 0,3 bar pressure on the bladder (15).
- 4 Fill the plastic funnel with the recommended oil and cover it.
- 5 Extend steadily and slowly the piston rod (13) until the oil level in the funnel drops something over the fill port.
- 6 Repeat point 4. and 5. until the piston rod (13) is fully extended.
- 7 Reduce the oil volume in the funnel so far that the piston rod volume will be less than the rest volume of the funnel.
- 8 Compress the piston rod steadily and slowly.
- 9 Pull the rod steadily and slowly into its max. extended position.
- 10 Repeat point 8. and 9. until you can not find any air bubbles in the oil.
- 11 If the damper is without air, remove the filling reservoir at the max. extended piston rod and install the fill plug (28) with the metallic sealing ring (41) and torque level of 50 Nm.



**12 (Valid for Bladder Version „long port plug“ only)**

- 12.1 Increase the bladder pressure to 3.5 bar or to the pressure given on the I.D. label (32).
- 12.2 Install the protective caps (15/1, 36) of the valve body and the port plug (10).

**13 (Valid for Bladder Version „short port plug“ only)**

- 13.1 Remove the protective cap (91) in the bearing (2) for getting access to the filling adapter (90)
- 13.2 Screw the filling adapter (90) into the port plug (10)
- 13.3 Increase the bladder pressure to 3.5 bar or to the pressure given on the I.D. label (32).
- 13.4 Unscrew the filling adapter (90) and store it in the bearing (2)
- 13.5 Install the protective caps (91, 36) of the bearing and the port plug (10).

14 Test the assembled shock absorber by compressing the piston rod. In a properly assembled and filled unit, the piston rod will return by itself to the max. extended position.

## FIELD REPAIR-INSTRUCTIONS SENSOR EXCHANGE

- 1 Loosen safety screw (75) with inner hex key (S = 1,5 mm).
- 2 Remove the lock nut (71) by turning counterclockwise with a screw driver .
- 3 Remove the sensor (73) out of the sensor housing (70).  
**CAUTION:**  
**THE SENSOR HOUSING (70) IS USED AS FILL PLUG; IT MUST NOT BE REMOVED OR LOOSEN.**
- 4 Insert a new sensor (73) into the sensor housing (70) until the sensor is bottoming in the housing.
- 5 Press the cable of the sensor through the slot of the lock nut (71). Remount the lock nut by using a screw driver (tightened with max. 2Nm)
- 6 Secure the lock nut (71) with set screw (75).

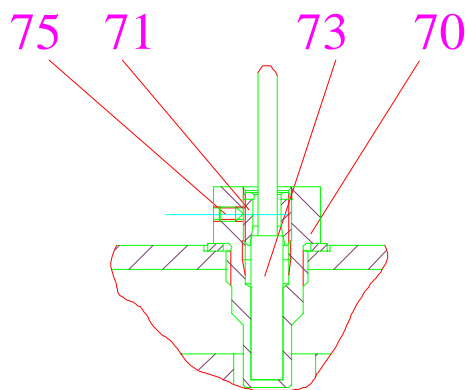

## SPAREPARTS

AMOUNT										SPAREPART	ITEM	PART-NUMBER
1	1	1	1	1	1	1	1	1	1	CYLINDER BASE	1	X - 1
1	1	1	1	1	1	1	1	1	1	BEARING ASSEMBLY	2	X - 1B
1	1	1	1	1	1	1	1	1	1	SHOCK TUBE ASSEMBLY	3	X - 2S
1	1	1	1	1	1	1	1	1	1	CYLINDER	4	X - 4
1	1	1	1	1	1	1	1	1	1	LOCK RING	5	X - 5
1	1	2	2	2	1	1	2	2	2	MOUNTING FLANGE	6	X - 6
--	--	--	2	1	--	--	--	2	1	FOOT MOUNT ASSEMBLY	9,43,44	X - 2F
1	1	1	1	1	1	1	1	1	1	PORT PLUG	10	X - 10
1	1	1	1	1	1	1	1	1	1	PISTON ROD	13	X - 13
1	1	1	1	1	1	1	1	1	1	PISTON CAP	14	X - 14
1	1	1	1	1	1	1	1	1	1	BLADDER	15	X - 15
1	1	1	1	1	1	1	1	1	1	SOCKET HEAD CAP SCREW	25	X - 25
1	1	1	1	1	--	--	--	--	--	FILL PLUG KIT	28,41	X - 7F
--	--	--	--	--	1	1	1	1	1	FILL PLUG KIT SENSOR	41,70,71,75	X - 7F
1	1	1	1	1	1	1	1	1	1	LABEL KIT	29,30,31,32	X - 1L
X	X	X	X	X	X	X	X	X	X	HYDRAULIK FLUID	33	X - 33
1	1	1	1	1	1	1	1	1	1	CAPLUG	36	X - 36
1	1	2	2	2	1	1	2	2	2	SOCKET HEAD SET SCREW	39	X - 39
2	2	4	4	4	2	2	4	4	4	SOCKET HEAD SET SCREW	40	X - 40
1	1	--	--	--	1	1	--	--	--	SPACER	42	X - 42
--	--	--	--	--	1	1	1	1	1	SENSOR	73	X - 73
1	1	1	1	1	1	1	1	1	1	FILLING ADAPTOR	90	X - 90
1	1	1	1	1	1	1	1	1	1	CAPLUG	91	X - 91
1	1	1	1	1	1	1	1	1	1	O-RING	92	X - 92
1	1	1	1	1	1	1	1	1	1	SEAL KIT	16,20,21,27,,38,41,92	X - SK
1	1	1	1	1	--	--	--	--	--	PISTON HEAD ASSEMBLY	7,8,12,23,24	X - 3P
--	--	--	--	--	1	1	1	1	1	PISTON HEAD ASSY SENSOR	7,8,12,23,24,72,74	X - 3P
HD 2.0 FF	HD 2.0 FR	HD 2.0 TF	HD 2.0 FM	HD 2.0 TM	HD 2.0 FF Sensor	HD 2.0 FR Sensor	HD 2.0 TF Sensor	HD 2.0 FM Sensor	HD 2.0 TM Sensor	<b>HD 2.0 SERIES</b>		

**X: to be replaced by partnumber of damper**

# HD 2.0 FF

SCHNITT B - B

SCHNITT A - A

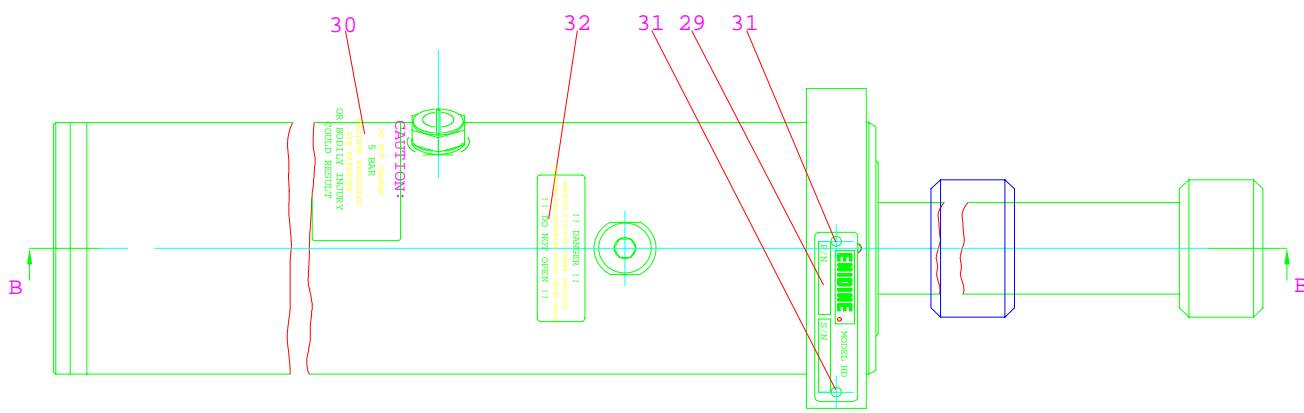
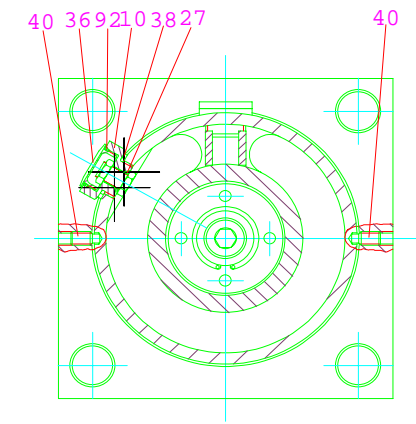
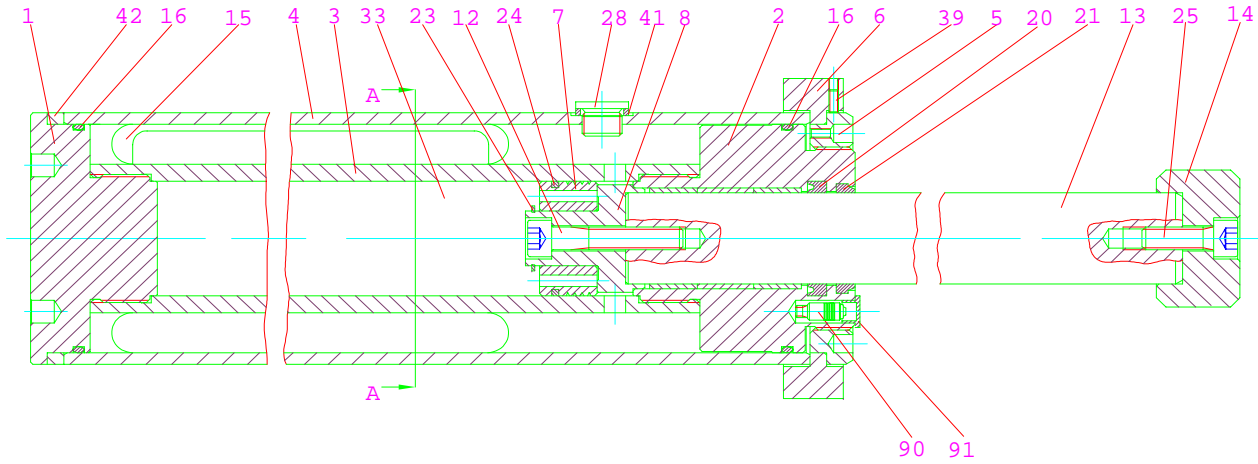

POS.	DESCRIPTION	DATE	APPROVED

DO NOT SCALE PRINT  
UNLESS OTHERWISE SPECIFIED  
DIMENSIONS ARE IN MILLIMETERS  
DIMENSIONS EXCL. TOLERANCES  
ISO 2768-M

ENIDINE GMBH  
POSTFACH 102  
D-79411 BAD WILDELINGEN  
HERFABRIKATION & LEIST. AUTOMATENBETRIEB

Ers. für: Ers. durch

**SPARE PARTS LIST**  
**HD 2.0**  
**FRONT FLANGE**

APP. [ ] DTD. NO. [ ] SKY [ ]  
CHECKED [ ]  
DRAWN [ ]  
MATERIAL: [ ]

SCALE: 1:1  
WORK: [ ]  
SHEET: 1 OF 2

# HD 2.0 FFC

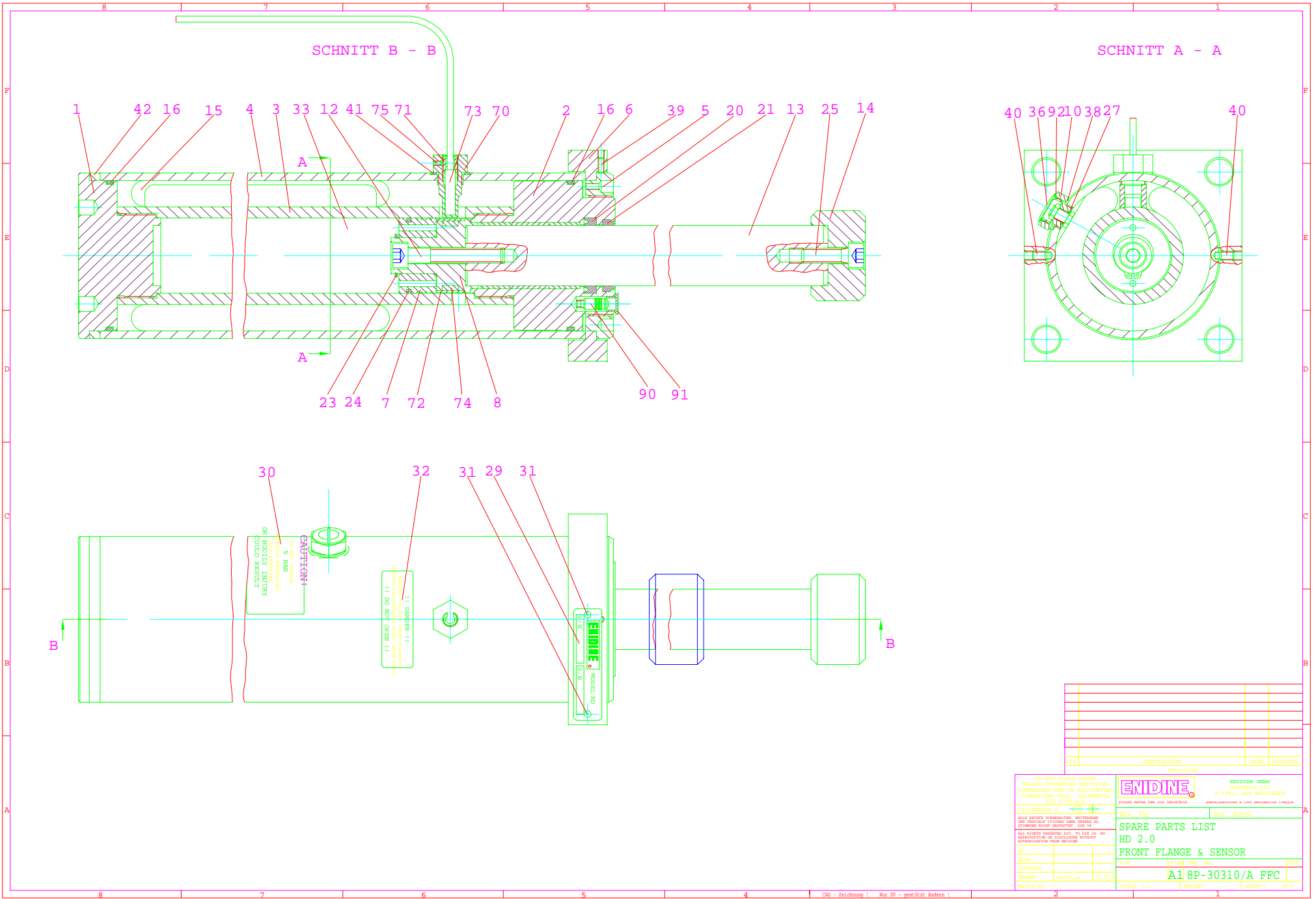















# HD 2.0 TM

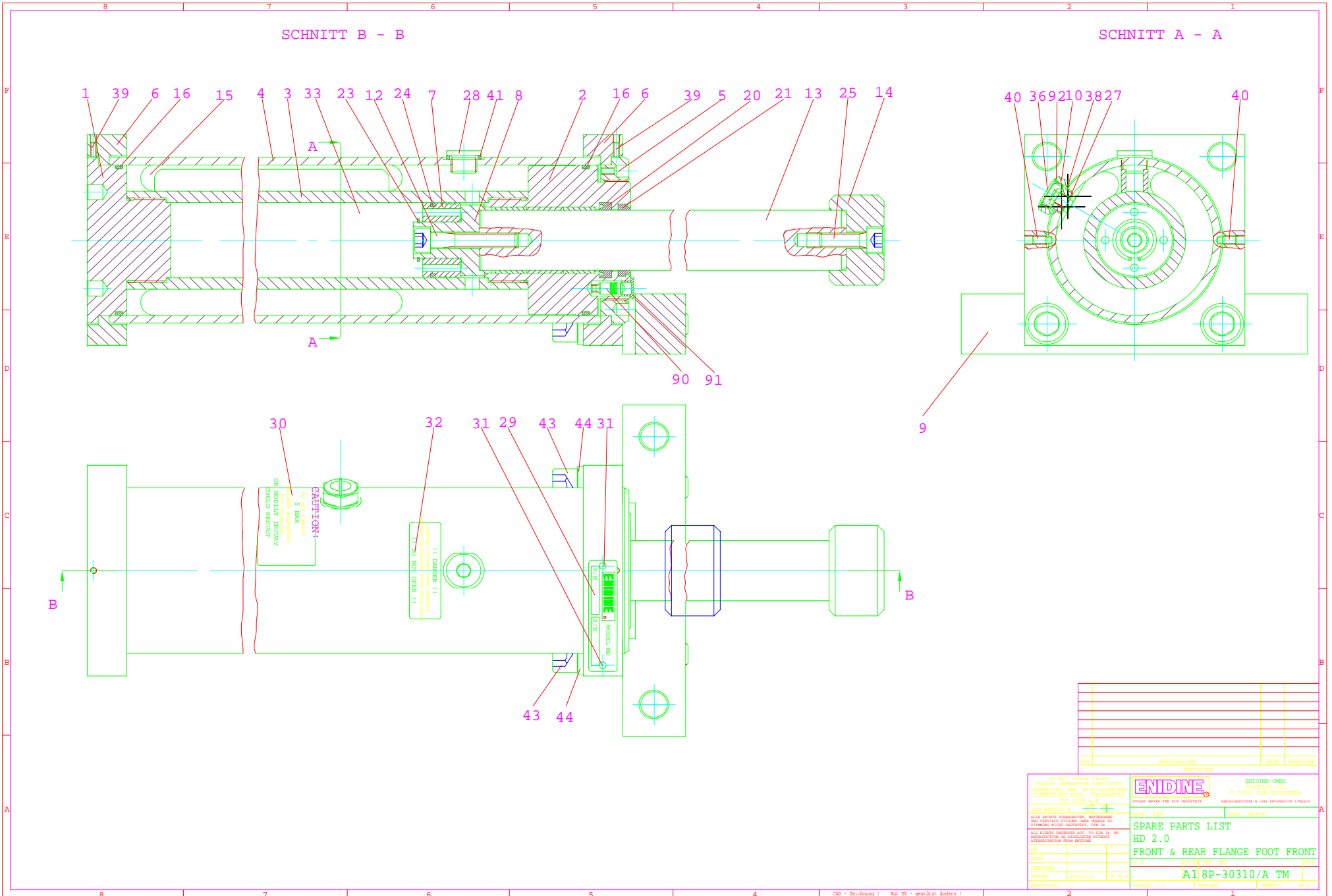

# HD 2.0 TMC

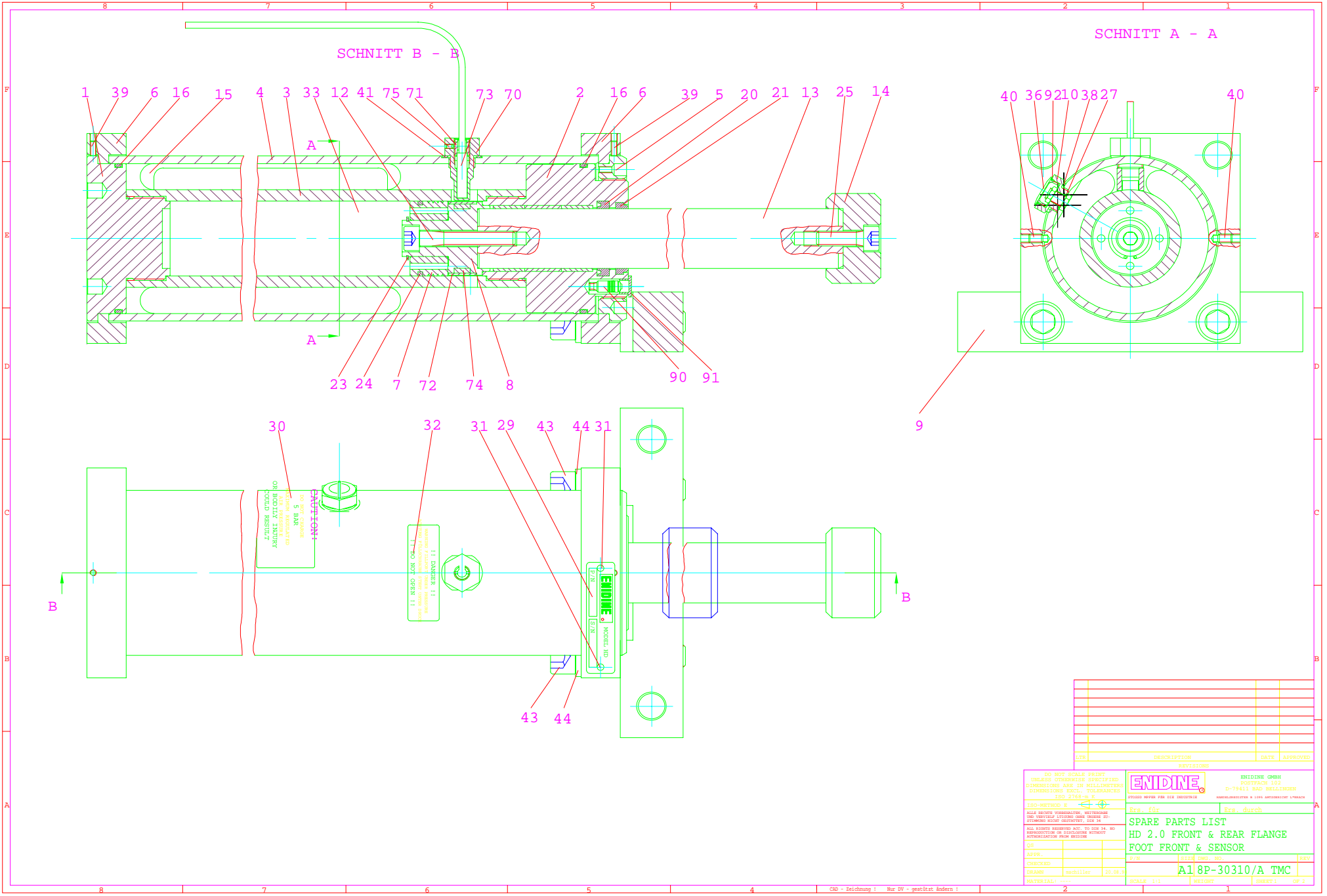

**CAUTION!**  
 5 BAR  
 OR SOFTLY INJURY  
 COULD RESULT

**!! DANGER !!**  
 11 BAR  
 OR SOFTLY INJURY  
 COULD RESULT

DO NOT SCALE PRINT UNLESS OTHERWISE SPECIFIED DIMENSIONS ARE IN MILLIMETERS DIMENSIONS EXCL. TOLERANCES ISO SYSTEM			
ENDINE GMBH POSTFACH 102 D-79411 BAD WILDELINGEN TELEFON (07841) 910-100 FAX (07841) 910-101		Ers. für: _____ Ers. durch: _____	
<b>SPARE PARTS LIST</b> <b>HD 2.0 FRONT &amp; REAR FLANGE</b> <b>FOOT FRONT &amp; SENSOR</b>			
QTY	UNIT	QTY	UNIT
1	PC	1	PC
MATERIAL: A18P-30310/A TMC		SCALE: 1:1	
DATE: 20.09.03		SHEET: 1 OF 2	