

# STABIFLEX

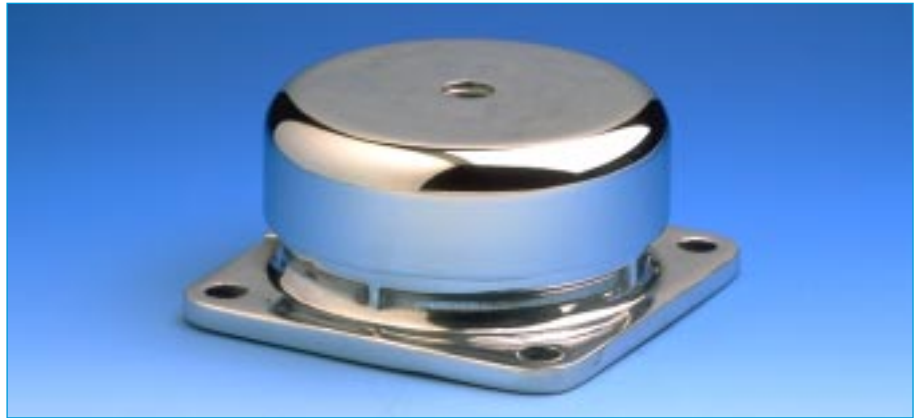

(1) Natural frequency :  
6 to 11 Hz

## DESCRIPTION

The STABIFLEX mounting comprises a conical rubber section bonded between inner and outer metal parts.

- Centre axis with threaded hole.
- Square (4 holes) or diamond base (2 holes) with clearance hole.
- Bonded natural rubber, anti-slip bead.
- Cup to protect the rubber and distribute the load.

## OPERATION

The design of the STABIFLEX mounting gives the following basic characteristics :

- Axial elasticity two or three times higher than radial elasticity.
- The rubber works in shear/compression.
- Progressive buffer against shocks or accidental overload.
- Anti-slip (may be placed directly on the ground).

### Advantages :

- The machine may be placed with its mountings directly on the ground.
- Speed of fixing.
- Easy movement of suspended machinery.
- Rubber protected against harmful liquids.
- Extensive range : 3 hardnesses of rubber for 5 existing types, allowing the mounting to be optimised as a function of the load and forcing frequency.
- May be used with an anti-rebound washer.

### Recommandations :

- In order not to affect the performances of the mounting system, all external connections must be flexible.
- STABIFLEX mountings must be fitted so that the vibration input is in the axial direction.

(1) Natural frequencies with max/min loads, see : OPERATING CHARACTERISTICS.



## DIMENSIONS

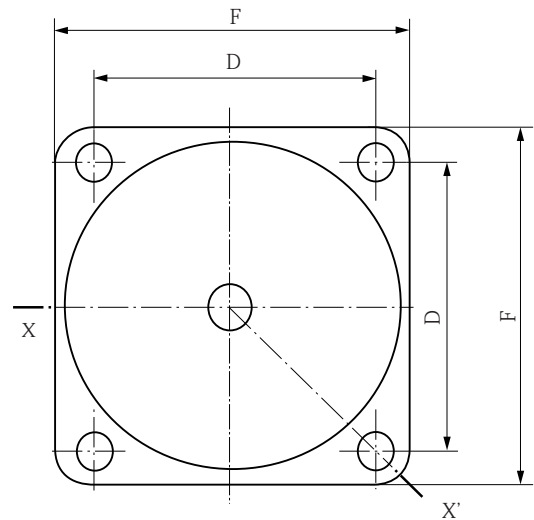
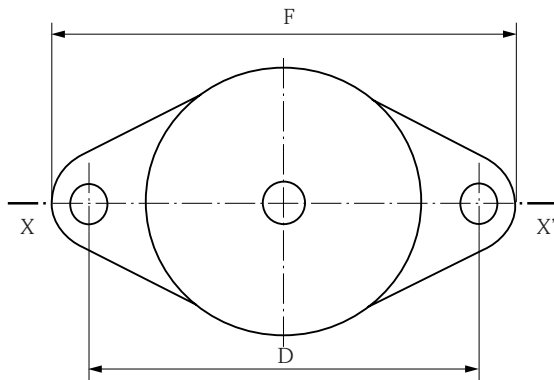
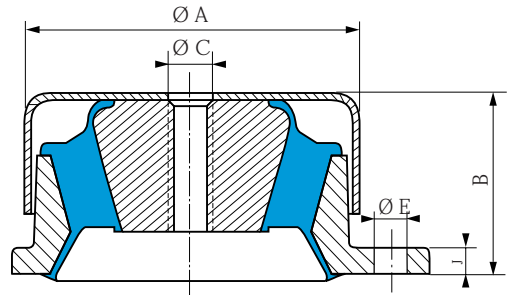
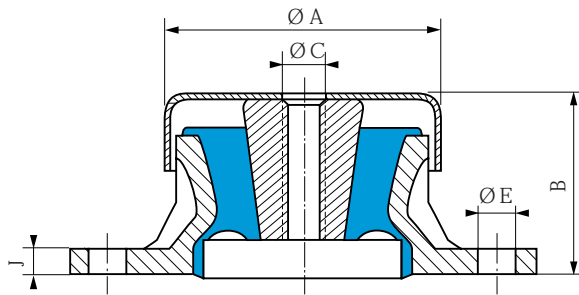

**STABIFLEX - diamond base**

**STABIFLEX - square base**

Type	Reference	Hardness	Ø A mm	B mm	Ø C mm	D mm	E mm	F mm	J mm	Weight g
Diamond base	<b>530603</b>	45.60.75	69	41	M 12	98	9	114	6	250
	<b>530613</b>	45.60.75	84	51	M 12	115	11	137	7	450
Square base	<b>530622</b>	45.60.75	100	52	M 12	90	11	114	7	1000
	<b>530642</b>	45.60	133	71	M 16	114	13	144	9	2300
	<b>530652*</b>	45.60.75	133	71	M 16	114	13	144	9	2700

\* Part identified by the letter "R" (reinforced)

See current price list for availability of items.

## OPERATING CHARACTERISTICS

Nominal static load daN	Deflection mm	Reference	Hardness
10 - 42	3.5	<b>530603</b>	45
15 - 60	3	<b>530603</b>	60
20 - 93	3.5	<b>530613</b>	45
30 - 125	4	<b>530603</b>	75
40 - 165	3.5	<b>530613</b>	60
50 - 210	5	<b>530622</b>	45
65 - 260	3	<b>530613</b>	75

Nominal static load daN	Deflection mm	Reference	Hardness
65 - 275	4.5	<b>530622</b>	60
95 - 380	3.5	<b>530622</b>	75
110 - 450	8	<b>530642</b>	45
175 - 700	8	<b>530642</b>	60
250 - 1000	8	<b>530652</b>	45
325 - 1300	8	<b>530652</b>	60
450 - 1800	8	<b>530652</b>	75



## LOAD/DEFLECTION CURVES IN AXIAL COMPRESSION

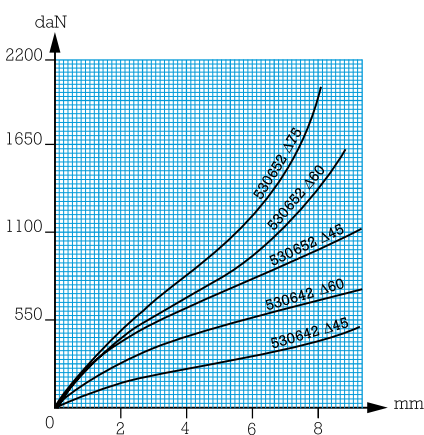
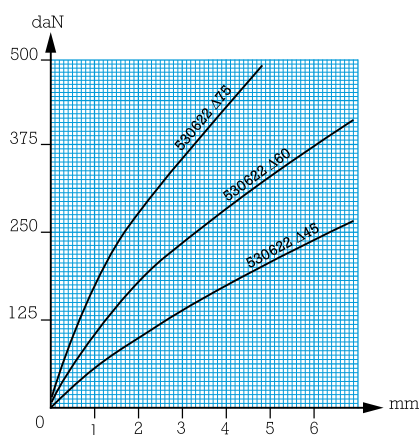
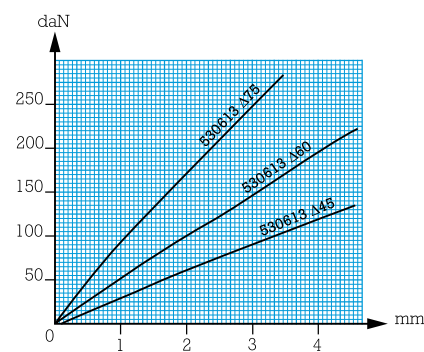
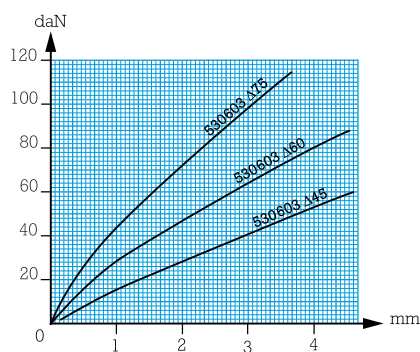

## ASSEMBLY

- Standard fixing methods

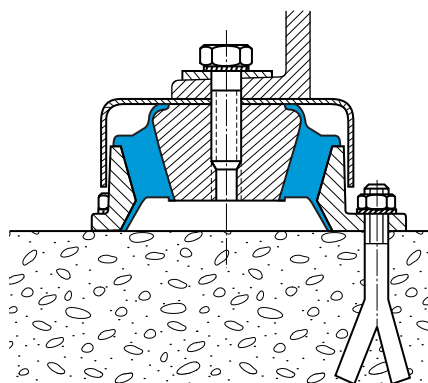
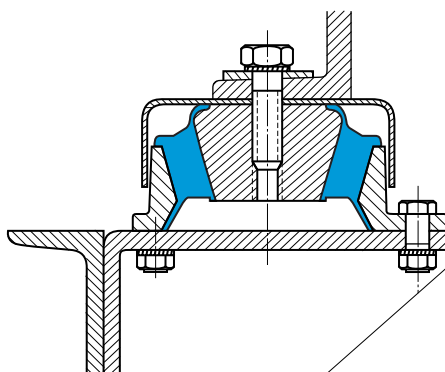

- Fixing with anti-rebound washer

- The anti-rebound washer (not supplied) is fixed to the lower side of the centre axis.
- In this case, do not forget to fit a spacer.

Spacer thickness required :

530603      h : 2 mm

530613      h : 4 mm

530622      h : 7 mm

530642      h : 14 mm

530652      h : 14 mm

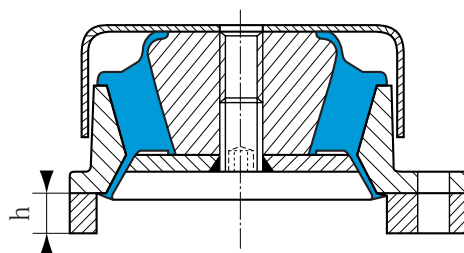

All our mountings are identified by conventional markings, either a paint spot or figures indicating the hardness : grey = hardness 45, green = hardness 60, blue = hardness 75.

