



## V118-MG V118-DG V318 V318-D

Natural frequency : (1)  
11 to 22 Hz

### DESCRIPTION

V118-MG and V318 mounts have cast iron cover and base with 4 mountings holes in the base and a central tapped hole in the cover.

The resilient elements are stainless steel wire mesh cushions :

- V118-MG and V318 have two cushions;
- V118-DG and V318-D have three cushions.

### APPLICATIONS

This series of mounts have a natural frequency between 18 and 25 Hz and can be used for mounting :

- heavy machinery (grinders, crushers, inclined presses, eccentric presses, printing presses, textile machines);
- rotating machines (motors, generator sets, pumps, etc), which rotate at more than 2000 rpm for V118-DG and V318-D and up to 2500 rpm for V118-MG and V318;
- gantry cranes (structure, cabs, equipment).

The isometric stiffness characteristics and anti-rebound metal cushions of these suspensions makes them suitable for suspending engines on ships, vehicles, etc.

As they can withstand temperatures between - 70°C and + 300°C, they can also be used for mounting exhaust pipes.

(1) Natural frequencies with max/min loads, see : OPERATING CHARACTERISTICS.



# DIMENSIONS

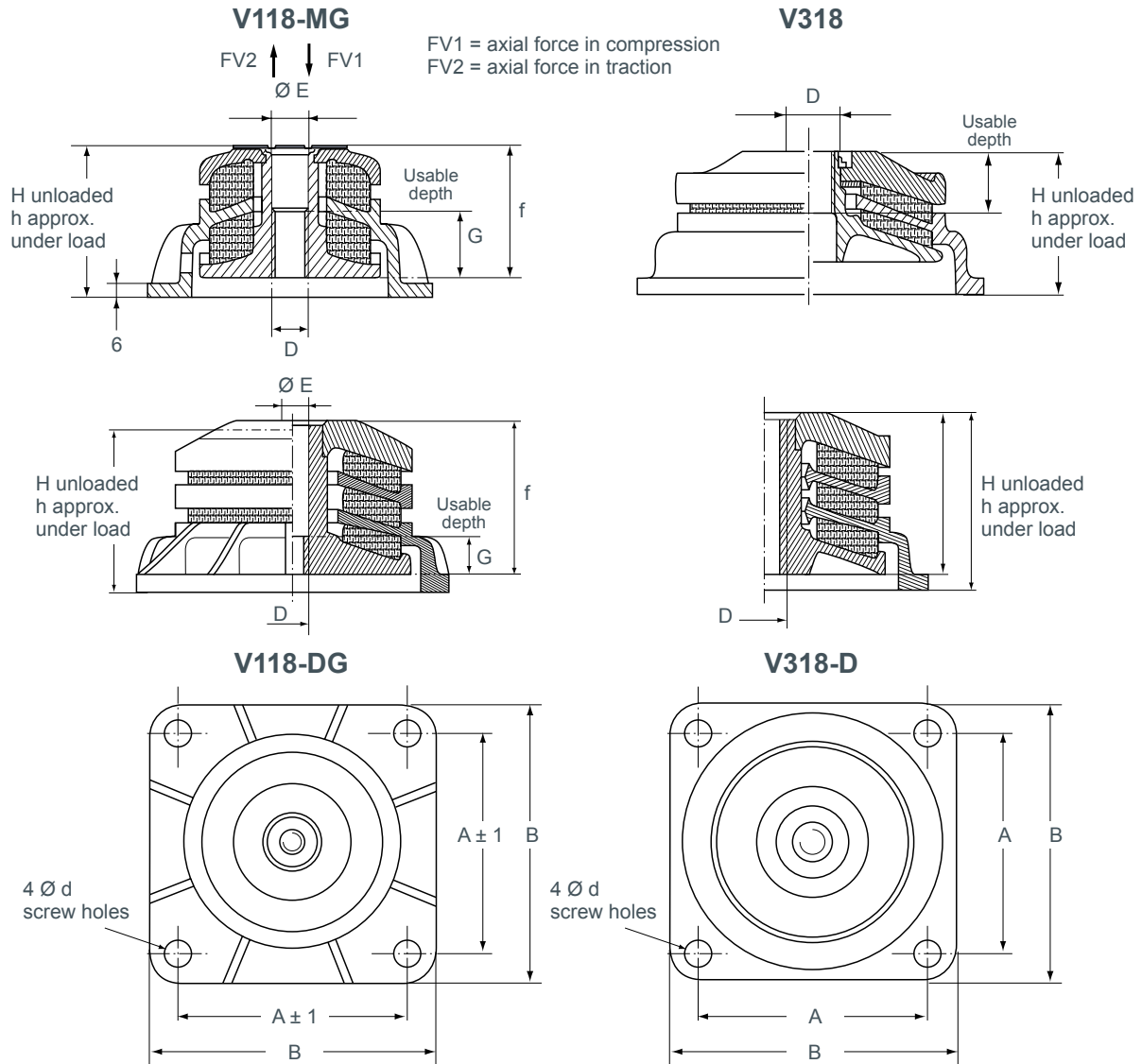

Reference	A (mm)	B (mm)	D	Ø E (mm)	G (mm)	H (mm)	Ø d (mm)	f (mm)	h under FV1 app. (mm)	h under FV2 app. (mm)
V118-MG	100	130	M16	16,5	30	73	12	63	68	77
V118-DG	100	130	M16	16,5	30	98	12,5	84	-	-
V318	170	220	M27	-	59	97	17	-	93	100
V318-D	170	220	M27	-	-	125	17	112	-	-

## Operating characteristics

- Maximum permitted excitation at natural frequency of suspension : ± 0.3 mm.
- Amplification factor at resonance : < 4.

Reference	Load range (daN)	Maximum dynamic forces (daN)			Natural frequency (Hz)	Weight of mounting (kg)
		Axial compression	Axial traction	Radial		
V118-MG V118-DG	50 à 900	4 500	1 500	1 500	16 to 22 11 to 17	2 2,4
V318 V318-D	250 à 7 000	21 000	9 000	7 500	16 to 22 11 to 17	10 13