



Compact Wire Rope Isolators

For the best in vibration isolation capabilities, choose Enidine's Compact Wire Rope Isolators. Smaller than traditional wire ropes, these unique isolators provide cost-effective, simultaneous shock and vibration attenuation where package space is at a premium.

Enidine Compact Wire Rope Isolators feature an easy, single-point installation, which allows them to be installed in virtually any application. Their small size also permits the isolation of individual system components, making them ideal for use in sensitive equipment and electronics. Just as with our standard Enidine Wire Rope Isolators, Enidine Compact Wire Rope Isolators feature a patented, all-metal design and components that ensure maximum reliability, regardless of temperature or substrate requirement, and that may help meet MILSPECs similar to those of our Wire Rope Isolator series. Please refer to our "Compact Wire Rope Isolator Sizing Information" on pages 37-38 for more information.

If your application is outside the standard Compact Wire Rope Isolator product range, please consult the standard Wire Rope Isolator or HERM portions of this catalog. If a standard solution is still not available, Enidine engineers can design an isolator to suit your specifications.

For further information on Enidine Wire Rope, HERM and Compact Wire Rope Isolator products, technical assistance and pricing, please contact Enidine or your nearest authorized distributor. A list of Enidine distributors can be found by visiting our website at www.enidine.com.

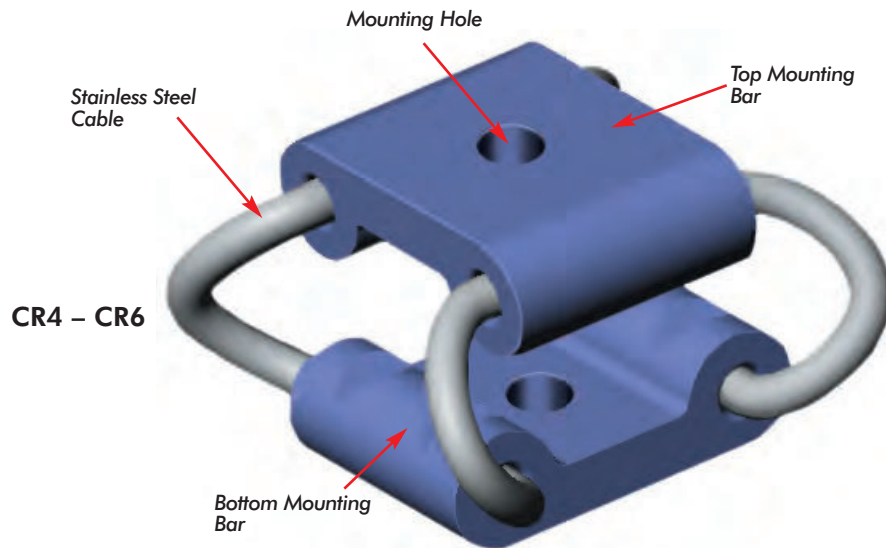
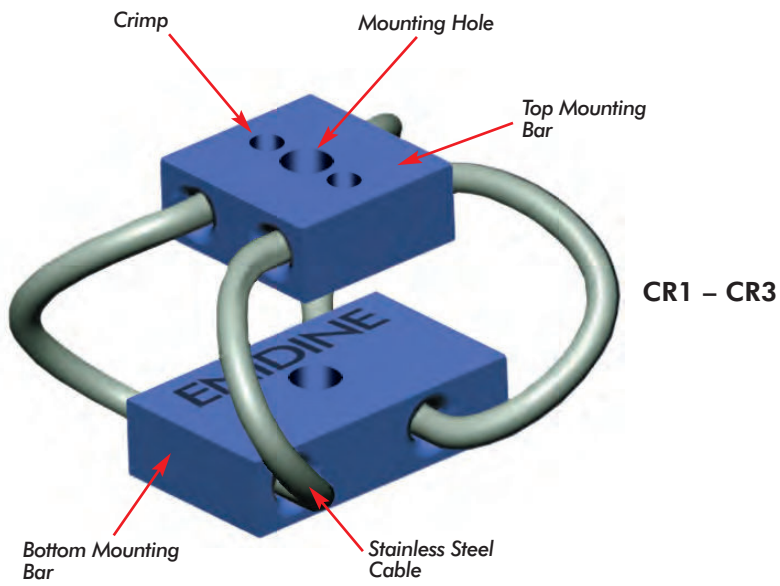

Materials and Finishes:

- Standard:** Wire Rope: 302/304 Stainless Steel
Mount Bars: 6061-T6 Aluminum, Chemical Conversion Coated per MIL-C-5541, Class 1A
Threads: Tapped
- Optional:** Mount Bars: 6061-T6 Aluminum, Anodized per MIL-A-8625, Type II, Class 1
302/304 Stainless Steel per ASTM A276, Passivated
- Special:** Consult Enidine

Isolator Options:

- Mounting:** Enidine offers a full range of mounting combinations of thru-hole, countersunk, and threaded bars. All configurations are available in either Imperial or Metric styles. Add an "M" after the mounting option for Metric. Some models have reduced mounting options available due to limited fastener installation space. Consult Enidine if a preferred mounting configuration is not listed.
- Bellmouth:** The bellmouth feature includes mount bars with radii manufactured into the wire rope hole edges. This option is recommended for high fatigue applications. Compact rope models (CR1 – CR6) include this feature as the standard.

Performance:**Stiffness (Kv or Ks):**

Compact wire rope isolators exhibit non-linear stiffness behavior. Small deflections, usually associated with vibration isolation, will have a different spring rate than larger shock deflections. Enidine publishes typical vibration stiffness values (Kv), and average shock stiffness values (Ks) within the catalog. These values can be used with the provided equations listed on Page 38 to predict system performance.

Isolator Axes:

Compact wire rope isolators are multi-axis isolators. The diagram below includes load axis definitions and deflection considerations.

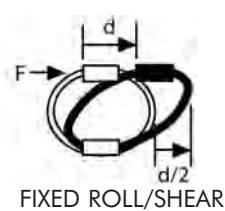
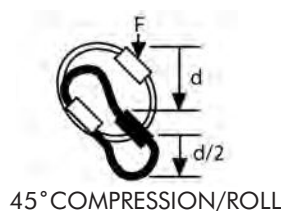
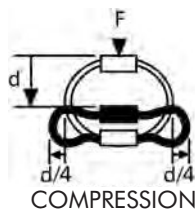

Damping: Typically 5-15%, depending on size and input level. For specific damping considerations, please consult Enidine.

Mounting Orientation:

The diagrams below illustrate typical mounting orientations.

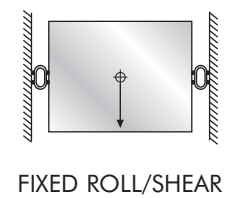
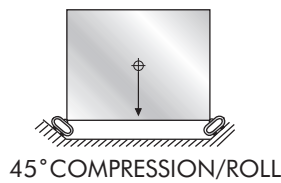
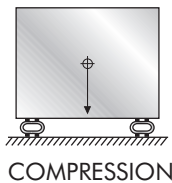
**Stabilizers:**

Stabilizers are used to control deflections of tall supported masses. Stabilizers are typically recommended when the height equals 2-times the width or depth dimension. In most applications, the quantity of stabilizers required are half as many as the base isolators, and selected one size softer than the base isolators.

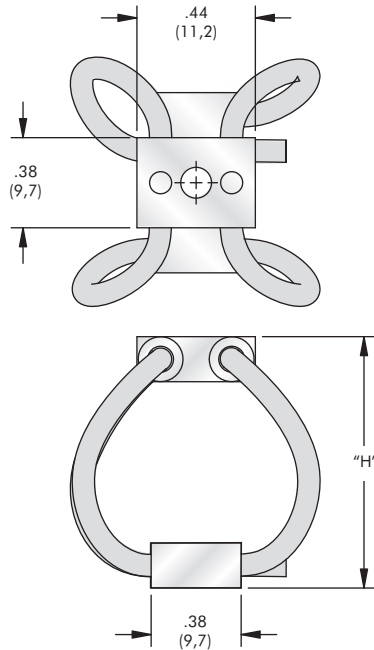

Note: Dimensions are in inches (mm)
Tolerances are ± .010 (± .25mm)

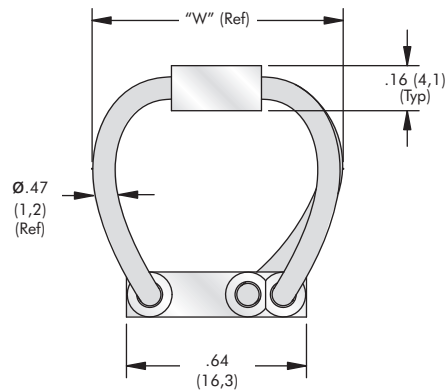

| Size | Height "H" in. (mm) | Width (Ref) "W" in. (mm) | Unit Weight oz. (g) | Mounting Options | Thru Hole in. (mm) | Thread in. (mm) | C'sink Imperial (Metric) |
|---------|---------------------------|--------------------------------|---------------------------|---------------------|--------------------------|-------------------------|--------------------------------|
| CR1-100 | 0.66 (17) | 0.73 (19) | 0.11 (3,1) | A, B, C, D, E, S | Ø.130 (Ø3,30) | #4-40 UNC (M3 X 0,5) | 82° (90°) |
| CR1-200 | 0.75 (19) | 0.79 (20) | 0.11 (3,1) | | | | |
| CR1-300 | 0.90 (23) | 0.91 (23) | 0.12 (3,4) | | | | |
| CR1-400 | 1.04 (26) | 1.03 (26) | 0.12 (3,4) | | | | |

Model Number Ordering Code

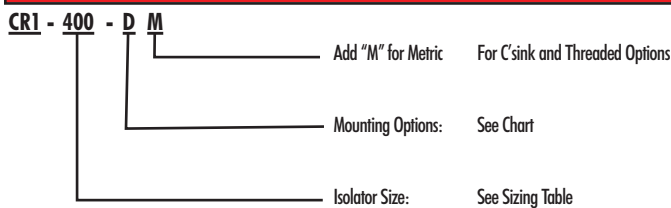

Mounting Options

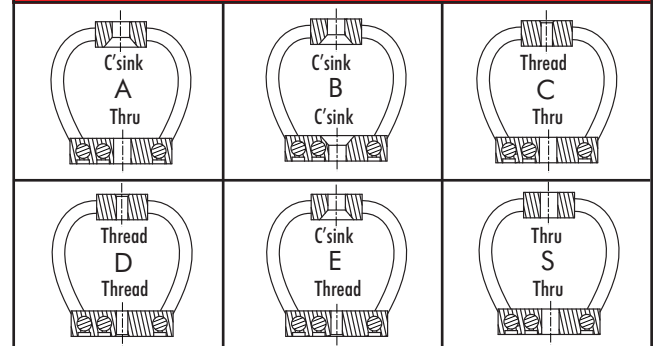

Wire Rope Special Options

Optional materials for the wire rope and mount bars are available upon request. Possibilities include galvanized rope, bell mouth mount bars or stainless steel rope and mount bars. Please contact Enidine to discuss in more detail. Minimum purchase quantities may apply. See page 37.

- Maximum recommended torque for tapped aluminum bar is 10 in.-lbs. (1,2 Nm)
- Wire Rope Material: Stranded 300 series stainless steel
- Operating Temperature Range: -150°F to 500°F (-100°C to 260°C)
- U.S. Patent 6,290,217

Static Load vs. Deflection

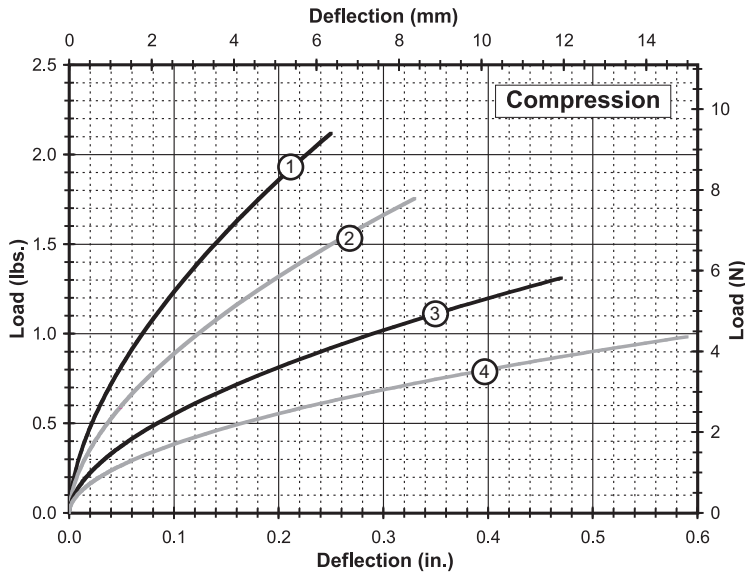

Compression

| Curve | Model | Max Static Load Lbs. (N) | Max Deflection in. (mm) | Kv (vibration) Lbs./in. (kN/m) | Ks (shock) Lbs./in. (kN/m) |
|-------|---------|--------------------------|-------------------------|--------------------------------|----------------------------|
| 1 | CR1-100 | 0.75 (3,3) | 0.25 (6,4) | 22 (3,9) | 11 (1,9) |
| 2 | CR1-200 | 0.55 (2,4) | 0.33 (8,4) | 16 (2,8) | 7.0 (1,2) |
| 3 | CR1-300 | 0.40 (1,8) | 0.47 (11,9) | 10 (1,75) | 3.5 (0,61) |
| 4 | CR1-400 | 0.30 (1,3) | 0.59 (15,0) | 7.5 (1,31) | 2.2 (0,39) |

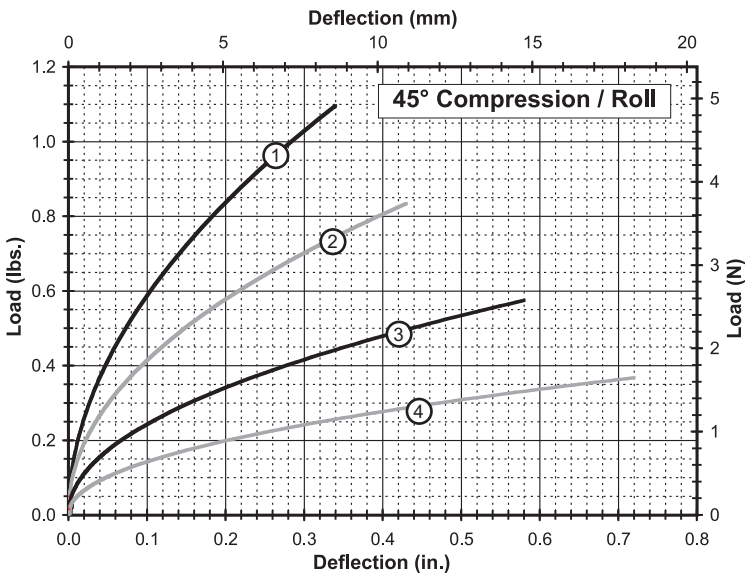

45° Compression/Roll

| Curve | Model | Max Static Load Lbs. (N) | Max Deflection in. (mm) | Kv (vibration) Lbs./in. (kN/m) | Ks (shock) Lbs./in. (kN/m) |
|-------|---------|--------------------------|-------------------------|--------------------------------|----------------------------|
| 1 | CR1-100 | 0.35 (1,6) | 0.34 (8,6) | 12 (2,1) | 4.5 (0,79) |
| 2 | CR1-200 | 0.25 (1,1) | 0.43 (10,9) | 8.5 (1,5) | 2.5 (0,44) |
| 3 | CR1-300 | 0.17 (0,76) | 0.58 (14,7) | 5.0 (0,88) | 1.5 (0,26) |
| 4 | CR1-400 | 0.11 (0,49) | 0.72 (18,3) | 3.0 (0,53) | 0.7 (0,12) |

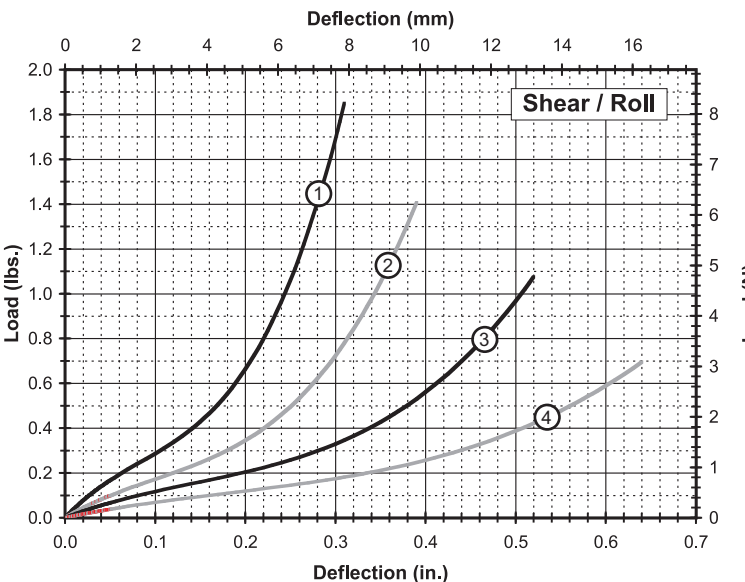

Shear/Roll

| Curve | Model | Max Static Load Lbs. (N) | Max Deflection in. (mm) | Kv (vibration) Lbs./in. (kN/m) | Ks (shock) Lbs./in. (kN/m) |
|-------|---------|--------------------------|-------------------------|--------------------------------|----------------------------|
| 1 | CR1-100 | 0.25 (1,1) | 0.31 (7,9) | 4.0 (0,70) | 4.0 (0,70) |
| 2 | CR1-200 | 0.20 (0,89) | 0.39 (9,9) | 2.5 (0,44) | 2.5 (0,44) |
| 3 | CR1-300 | 0.16 (0,71) | 0.52 (13,2) | 1.5 (0,26) | 1.5 (0,26) |
| 4 | CR1-400 | 0.12 (0,53) | 0.64 (16,3) | 0.8 (0,13) | 0.8 (0,13) |

Note: Do not extrapolate plotted curves.

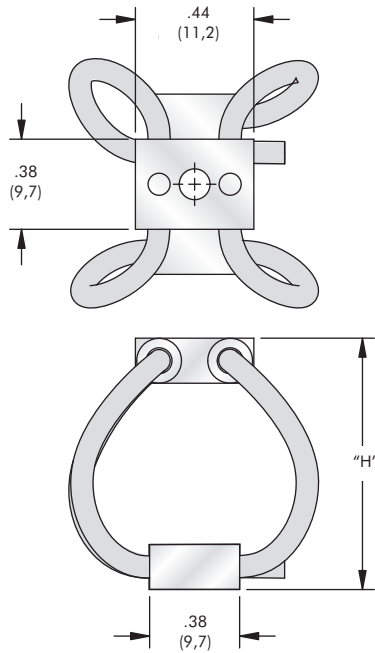

Note: Dimensions are in inches (mm)
Tolerances are $\pm .010$ ($\pm .25$ mm)

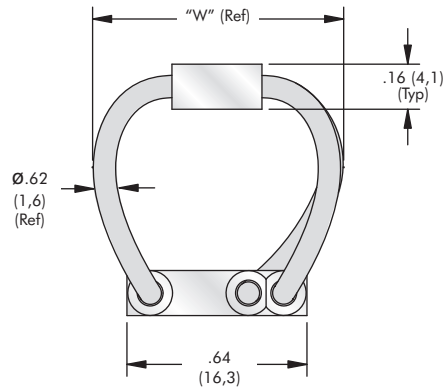

| Size | Height "H" in. (mm) | Width (Ref) "W" in. (mm) | Unit Weight oz. (g) | Mounting Options | Thru Hole in. (mm) | Thread in. (mm) | C'sink Imperial (Metric) |
|---------|---------------------------|--------------------------------|---------------------------|---------------------|--------------------------|-------------------------|--------------------------------|
| CR2-100 | 0.64 (16) | 0.78 (20) | 0.13 (3,7) | A, B, C, D, E, S | Ø.130 (Ø3.30) | #4-40 UNC (M3 X 0,5) | 82° (90°) |
| CR2-200 | 0.75 (19) | 0.83 (21) | 0.14 (4,0) | | | | |
| CR2-300 | 0.89 (23) | 0.94 (24) | 0.15 (4,3) | | | | |
| CR2-400 | 1.07 (27) | 1.06 (27) | 0.16 (4,5) | | | | |

Model Number Ordering Code

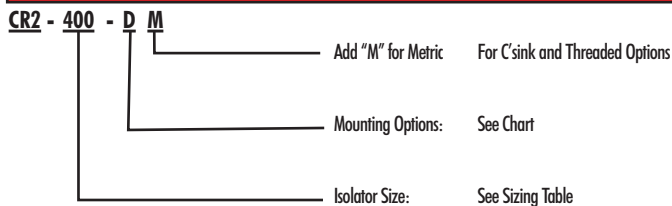

Mounting Options

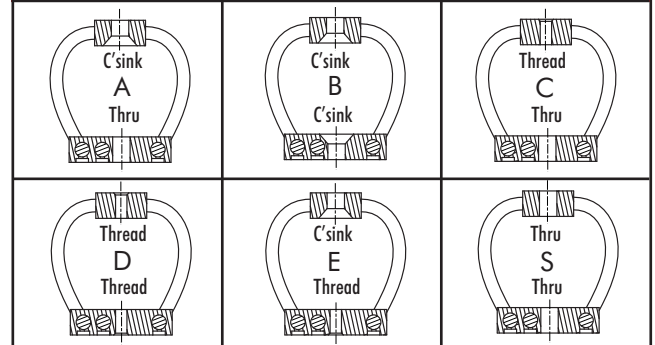

Wire Rope Special Options

Optional materials for the wire rope and mount bars are available upon request. Possibilities include galvanized rope, bell mouth mount bars or stainless steel rope and mount bars. Please contact Enidine to discuss in more detail. Minimum purchase quantities may apply. See page 37.

- Maximum recommended torque for tapped aluminum bar is 10 in.-lbs. (1,2 Nm)
- Wire Rope Material: Stranded 300 series stainless steel
- Operating Temperature Range: -150°F to 500°F (-100°C to 260°C)
- U.S. Patent 6,290,217

Static Load vs. Deflection

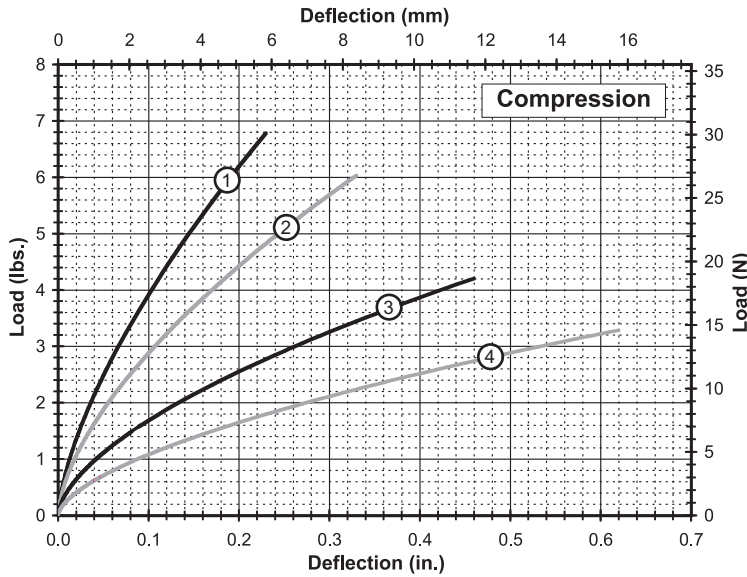

Compression

| Curve | Model | Max Static Load Lbs. (N) | Max Deflection in. (mm) | Kv (vibration) Lbs./in. (kN/m) | Ks (shock) Lbs./in. (kN/m) |
|-------|---------|--------------------------|-------------------------|--------------------------------|----------------------------|
| 1 | CR2-100 | 2.6 (12) | 0.23 (5,8) | 65 (11) | 35 (6,1) |
| 2 | CR2-200 | 2.1 (9,3) | 0.33 (8,4) | 50 (8,8) | 23 (4,0) |
| 3 | CR2-300 | 1.5 (6,7) | 0.46 (11,7) | 30 (5,3) | 11 (1,9) |
| 4 | CR2-400 | 1.1 (4,9) | 0.62 (15,7) | 20 (3,5) | 7 (1,2) |

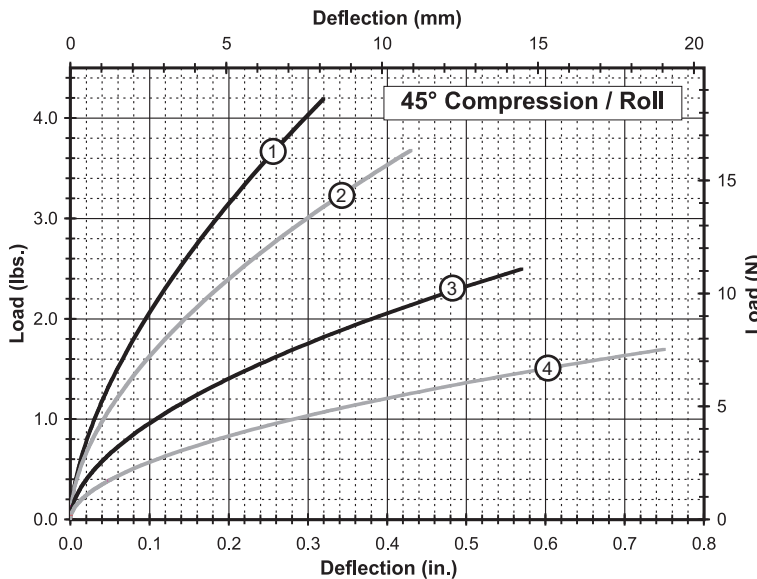

45° Compression/Roll

| Curve | Model | Max Static Load Lbs. (N) | Max Deflection in. (mm) | Kv (vibration) Lbs./in. (kN/m) | Ks (shock) Lbs./in. (kN/m) |
|-------|---------|--------------------------|-------------------------|--------------------------------|----------------------------|
| 1 | CR2-100 | 1.3 (5,8) | 0.32 (8,1) | 35 (6,1) | 16 (2,8) |
| 2 | CR2-200 | 1.1 (4,9) | 0.43 (10,9) | 30 (5,3) | 11 (1,9) |
| 3 | CR2-300 | 0.75 (3,3) | 0.57 (14,5) | 18 (3,2) | 6 (1,0) |
| 4 | CR2-400 | 0.50 (2,2) | 0.75 (19,1) | 11 (1,9) | 3 (0,51) |

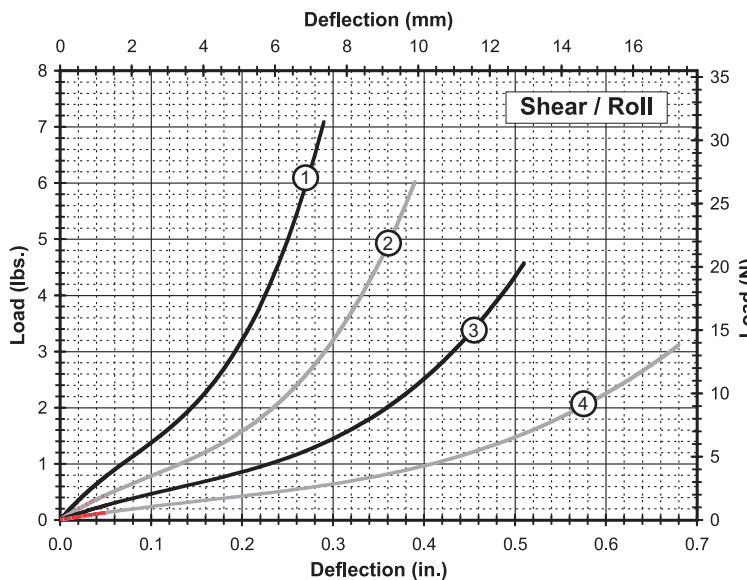

Shear/Roll

| Curve | Model | Max Static Load Lbs. (N) | Max Deflection in. (mm) | Kv (vibration) Lbs./in. (kN/m) | Ks (shock) Lbs./in. (kN/m) |
|-------|---------|--------------------------|-------------------------|--------------------------------|----------------------------|
| 1 | CR2-100 | 1.3 (5,6) | 0.29 (7,4) | 17 (3,0) | 17 (3,0) |
| 2 | CR2-200 | 0.90 (4,0) | 0.39 (9,9) | 10 (1,8) | 10 (1,8) |
| 3 | CR2-300 | 0.65 (2,9) | 0.51 (13,0) | 6 (1,1) | 6 (1,1) |
| 4 | CR2-400 | 0.45 (2,0) | 0.68 (17,3) | 3 (0,53) | 3 (0,53) |

Note: Do not extrapolate plotted curves.

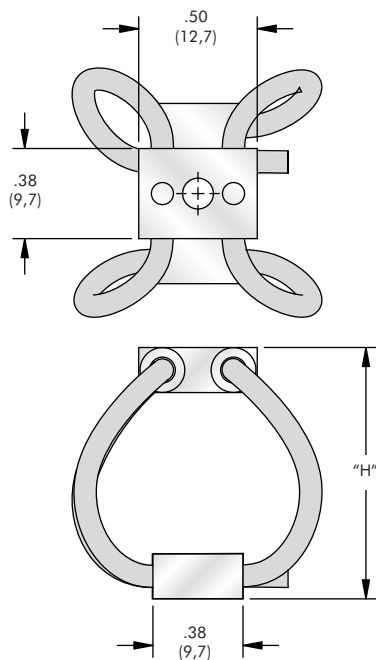

Note: Dimensions are in inches (mm)
Tolerances are $\pm .010$ ($\pm .25$ mm)

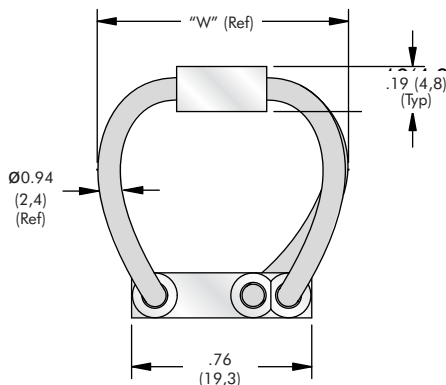

| Size | Height "H" in. (mm) | Width "W" in. (mm) | Unit Weight oz. (g) | Mounting Options | Thru Hole in. (mm) | Thread in. (mm) | C'sink Imperial (Metric) |
|---------|---------------------|--------------------|---------------------|------------------|--------------------|----------------------|--------------------------|
| CR3-100 | 0.75 (19) | 0.88 (22) | 0.20 (5,7) | A, B, C, D, E, S | Ø.130 (Ø3,30) | #4-40 UNC (M3 X 0,5) | 82° (90°) |
| CR3-200 | 0.90 (23) | 0.95 (24) | 0.22 (6,2) | | | | |
| CR3-300 | 1.06 (27) | 1.06 (27) | 0.24 (6,8) | | | | |
| CR3-400 | 1.28 (33) | 1.20 (30) | 0.26 (7,4) | | | | |

Model Number Ordering Code

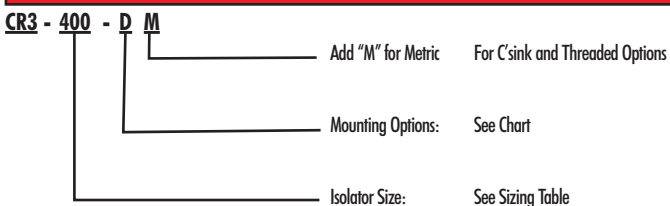

Mounting Options

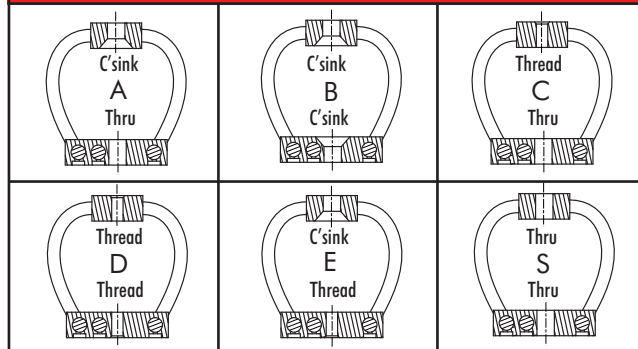

Wire Rope Special Options

Optional materials for the wire rope and mount bars are available upon request. Possibilities include galvanized rope, bell mouth mount bars or stainless steel rope and mount bars. Please contact Enidine to discuss in more detail. Minimum purchase quantities may apply. See page 37.

- Maximum recommended torque for tapped aluminum bar is 13 in.-lbs. (1,5 Nm)
- Wire Rope Material: Stranded 300 series stainless steel
- Operating Temperature Range: -150°F to 500°F (-100°C to 260°C)
- U.S. Patent 6,290,217

Static Load vs. Deflection

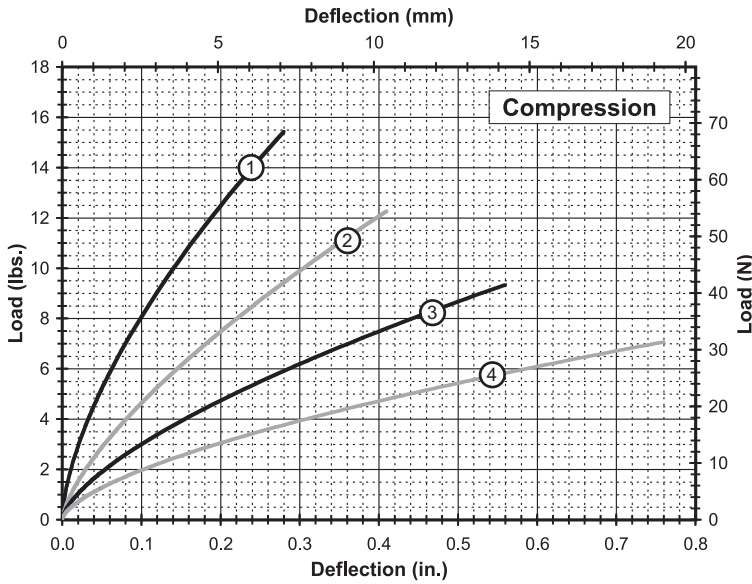

Compression

| Curve | Model | Max Static Load Lbs. (N) | Max Deflection in. (mm) | Kv (vibration) Lbs./in. (kN/m) | Ks (shock) Lbs./in. (kN/m) |
|-------|---------|--------------------------|-------------------------|--------------------------------|----------------------------|
| 1 | CR3-100 | 6.5 (29) | 0.28 (7,1) | 135 (24) | 68 (12) |
| 2 | CR3-200 | 5.0 (22) | 0.41 (10,4) | 70 (12) | 35 (6,1) |
| 3 | CR3-300 | 4.0 (18) | 0.56 (14,2) | 48 (8,4) | 20 (3,5) |
| 4 | CR3-400 | 2.5 (11) | 0.76 (19,3) | 33 (5,8) | 11 (1,9) |

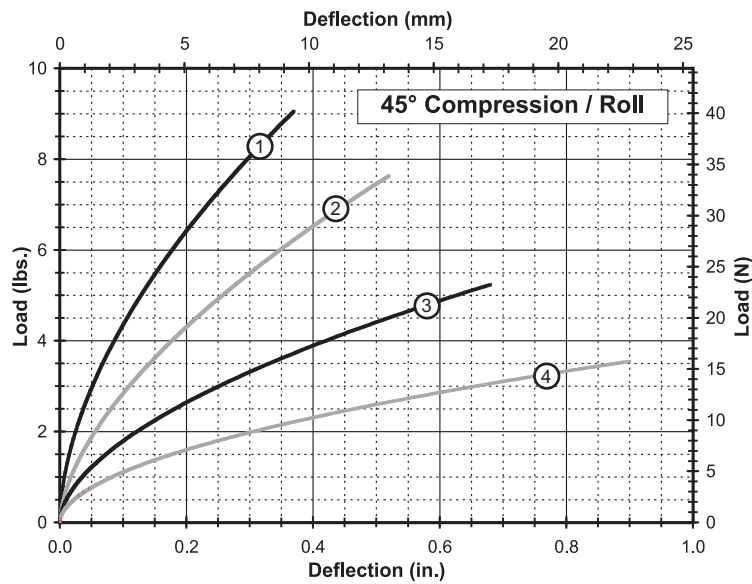

45° Compression/Roll

| Curve | Model | Max Static Load Lbs. (N) | Max Deflection in. (mm) | Kv (vibration) Lbs./in. (kN/m) | Ks (shock) Lbs./in. (kN/m) |
|-------|---------|--------------------------|-------------------------|--------------------------------|----------------------------|
| 1 | CR3-100 | 2.7 (12) | 0.37 (9,4) | 80 (14) | 30 (5,3) |
| 2 | CR3-200 | 2.3 (10) | 0.52 (13,2) | 50 (8,8) | 18 (3,2) |
| 3 | CR3-300 | 1.5 (6,7) | 0.68 (17,3) | 33 (5,8) | 10 (1,8) |
| 4 | CR3-400 | 1.0 (4,4) | 0.90 (22,9) | 20 (3,5) | 5 (0,91) |

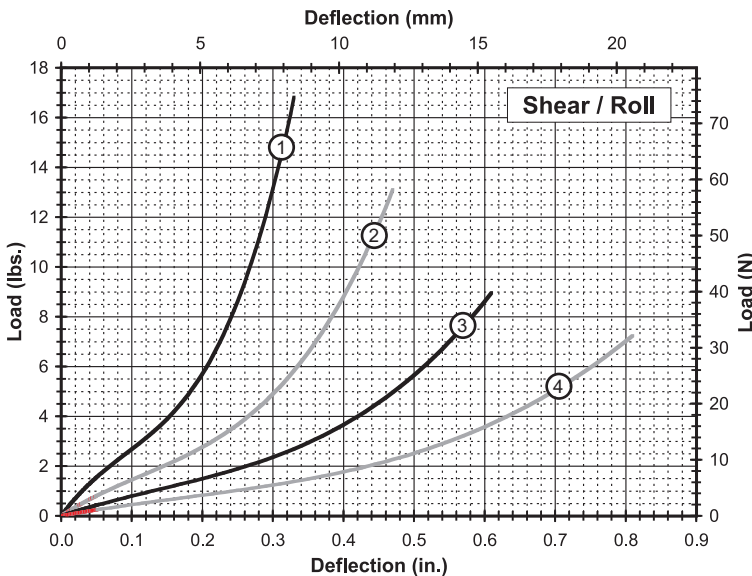

Shear/Roll

| Curve | Model | Max Static Load Lbs. (N) | Max Deflection in. (mm) | Kv (vibration) Lbs./in. (kN/m) | Ks (shock) Lbs./in. (kN/m) |
|-------|---------|--------------------------|-------------------------|--------------------------------|----------------------------|
| 1 | CR3-100 | 2.7 (12) | 0.33 (8,4) | 35 (6,1) | 35 (6,1) |
| 2 | CR3-200 | 1.9 (8,5) | 0.47 (11,9) | 20 (3,5) | 20 (3,5) |
| 3 | CR3-300 | 1.4 (6,2) | 0.61 (15,5) | 10 (1,8) | 10 (1,8) |
| 4 | CR3-400 | 1.0 (4,4) | 0.81 (20,6) | 6 (1,1) | 6 (1,1) |

Note: Do not extrapolate plotted curves.

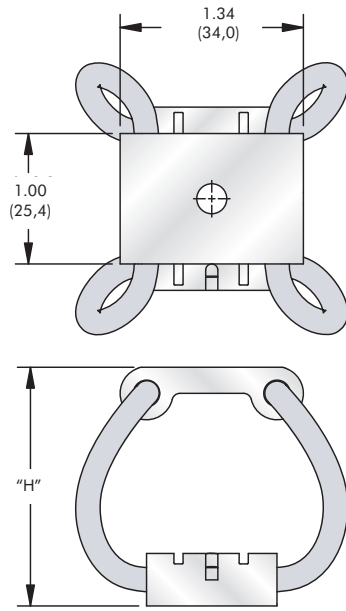

Note: Dimensions are in inches (mm)
Tolerances are ± .010 (± .25mm)

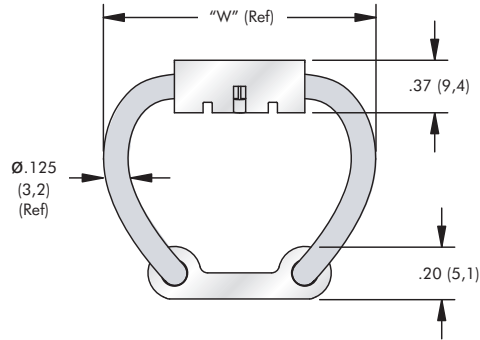

| Size | Height "H" in. (mm) | Width (Ref) "W" in. (mm) | Unit Weight oz. (g) | Mounting Options | Thru Hole in. (mm) | Thread in. (mm) | C'sink Imperial (Metric) |
|---------|---------------------|--------------------------|---------------------|------------------|--------------------|-----------------------|--------------------------|
| CR4-100 | 1.66 (42) | 1.87 (47) | 1.4 (40) | A, B, C, D, E, S | Ø.230 (Ø7,00) | #10-32 UNF (M6 X 1,0) | 82° (90°) |
| CR4-200 | 2.10 (53) | 2.12 (54) | 1.4 (40) | | | | |
| CR4-300 | 2.37 (60) | 2.34 (59) | 1.5 (43) | | | | |
| CR4-400 | 2.96 (75) | 2.67 (68) | 1.7 (48) | | | | |

Model Number Ordering Code

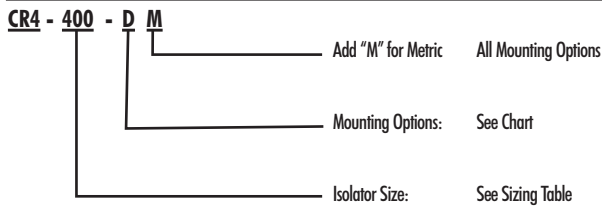

Mounting Options

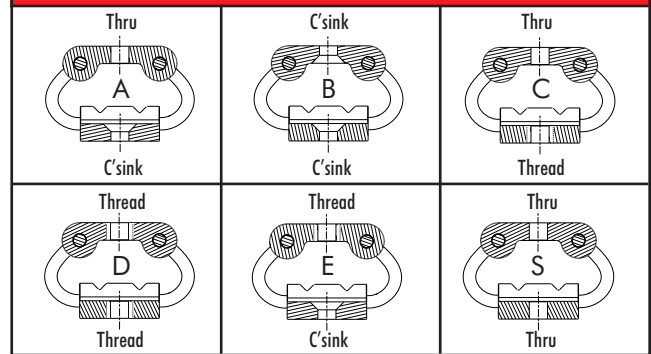

Wire Rope Special Options

Optional materials for the wire rope and mount bars are available upon request. Possibilities include galvanized rope, bell mouth mount bars or stainless steel rope and mount bars. Please contact Enidine to discuss in more detail. Minimum purchase quantities may apply. See page 37.

- Maximum recommended torque for tapped aluminum bar is 40 in.-lbs. (7,5 Nm)
- Wire Rope Material: Stranded 300 series stainless steel
- Operating Temperature Range: -150°F to 500°F (-100°C to 260°C)
- U.S. Patent 6,244,579

Static Load vs. Deflection

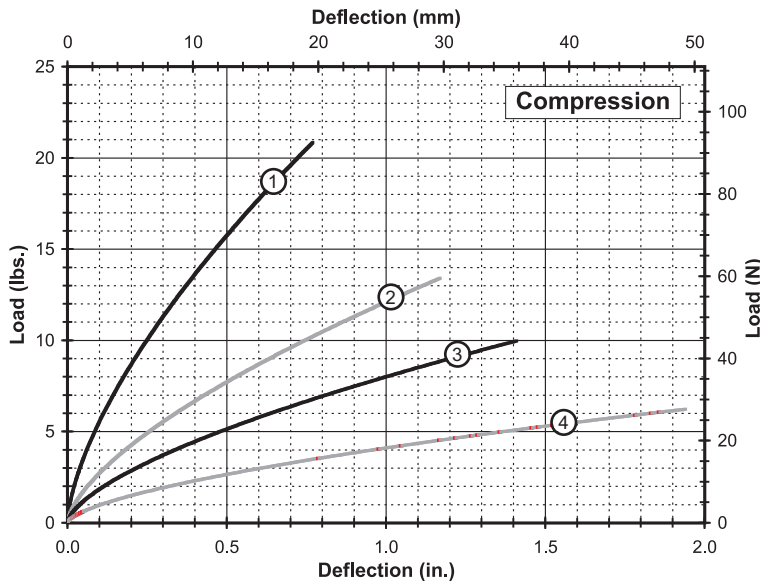

Compression

| Curve | Model | Max Static Load Lbs. (N) | Max Deflection in. (mm) | Kv (vibration) Lbs./in. (kN/m) | Ks (shock) Lbs./in. (kN/m) |
|-------|---------|--------------------------|-------------------------|--------------------------------|----------------------------|
| 1 | CR4-100 | 5.5 (24) | 0.77 (19,6) | 70 (12) | 33 (5,8) |
| 2 | CR4-200 | 4.0 (18) | 1.17 (29,7) | 35 (6,0) | 14 (2,5) |
| 3 | CR4-300 | 3.0 (13) | 1.41 (35,8) | 25 (4,4) | 9 (1,6) |
| 4 | CR4-400 | 1.5 (6,7) | 1.94 (49,3) | 12 (2,2) | 4 (0,70) |

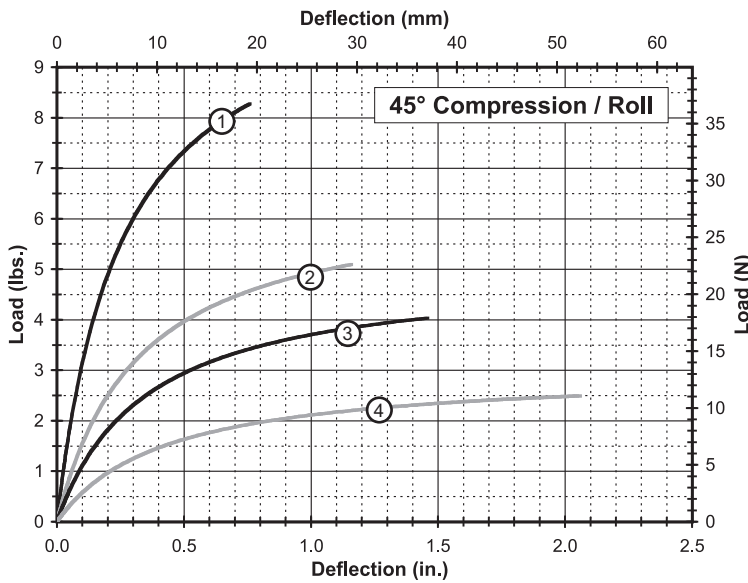

45° Compression/Roll

| Curve | Model | Max Static Load Lbs. (N) | Max Deflection in. (mm) | Kv (vibration) Lbs./in. (kN/m) | Ks (shock) Lbs./in. (kN/m) |
|-------|---------|--------------------------|-------------------------|--------------------------------|----------------------------|
| 1 | CR4-100 | 2.5 (11) | 0.76 (19,3) | 37 (6,4) | 16 (2,8) |
| 2 | CR4-200 | 1.5 (6,7) | 1.16 (29,5) | 18 (3,1) | 6 (1,1) |
| 3 | CR4-300 | 1.2 (5,3) | 1.46 (37,1) | 13 (2,2) | 4 (0,70) |
| 4 | CR4-400 | 0.80 (3,6) | 2.06 (52,3) | 6 (1,1) | 2 (0,35) |

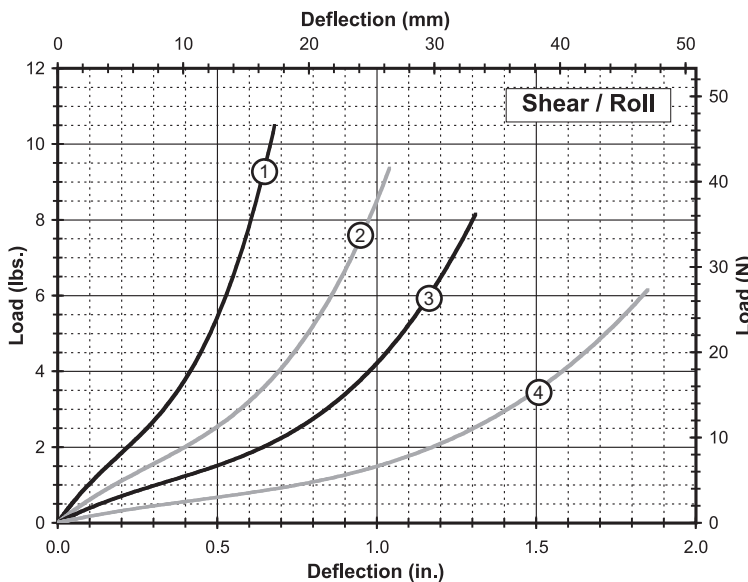

Shear/Roll

| Curve | Model | Max Static Load Lbs. (N) | Max Deflection in. (mm) | Kv (vibration) Lbs./in. (kN/m) | Ks (shock) Lbs./in. (kN/m) |
|-------|---------|--------------------------|-------------------------|--------------------------------|----------------------------|
| 1 | CR4-100 | 1.9 (8,5) | 0.68 (17,3) | 11 (1,9) | 11 (1,9) |
| 2 | CR4-200 | 1.6 (7,1) | 1.04 (26,4) | 6 (1,1) | 6 (1,1) |
| 3 | CR4-300 | 1.2 (5,3) | 1.31 (33,3) | 4 (0,70) | 4 (0,70) |
| 4 | CR4-400 | 0.75 (3,3) | 1.85 (47,0) | 2 (0,35) | 2 (0,35) |

Note: Do not extrapolate plotted curves.

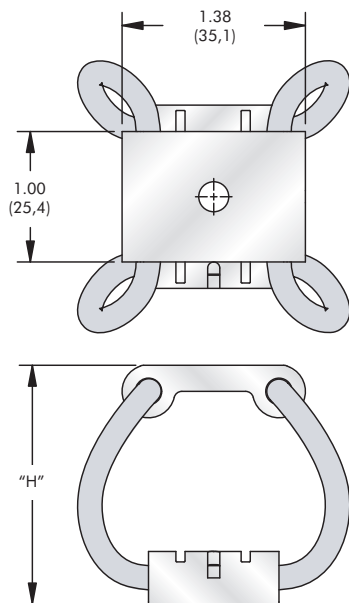

Note: Dimensions are in inches (mm)
Tolerances are ± .010 (± .25mm)

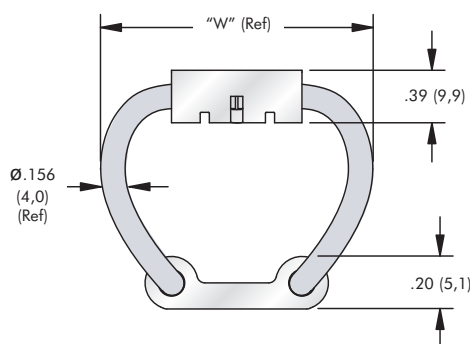

| Size | Height "H" in. (mm) | Width (Ref) "W" in. (mm) | Unit Weight oz. (g) | Mounting Options | Thru Hole in. (mm) | Thread in. (mm) | C'sink Imperial (Metric) |
|---------|---------------------------|--------------------------------|---------------------------|---------------------|--------------------------|--------------------------|--------------------------------|
| CR5-100 | 1.60 (41) | 1.89 (48) | 1.6 (45) | A, B, C, D, E, S | Ø.230 (Ø7,00) | #10-32 UNF (M6 X 1,0) | 82° (90°) |
| CR5-200 | 2.09 (53) | 2.13 (54) | 1.7 (48) | | | | |
| CR5-300 | 2.36 (60) | 2.32 (59) | 1.8 (51) | | | | |
| CR5-400 | 2.99 (76) | 2.64 (67) | 2.0 (57) | | | | |

Model Number Ordering Code

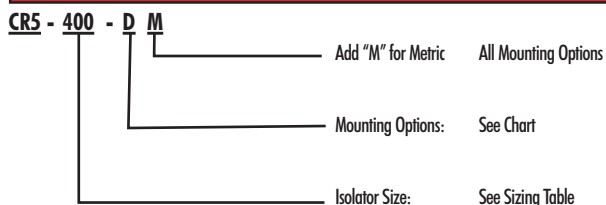

Mounting Options

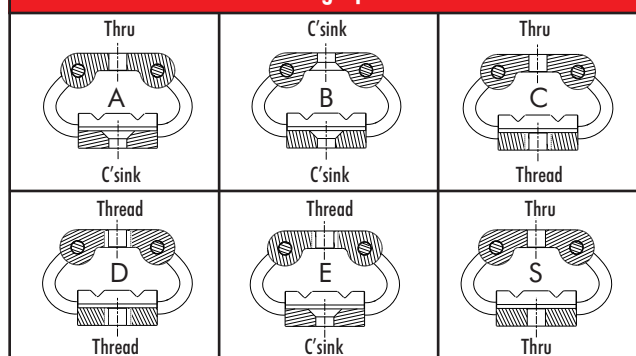

Wire Rope Special Options

Optional materials for the wire rope and mount bars are available upon request. Possibilities include galvanized rope, bell mouth mount bars or stainless steel rope and mount bars. Please contact Enidine to discuss in more detail. Minimum purchase quantities may apply. See page 37.

- Maximum recommended torque for tapped aluminum bar is 40 in.-lbs. (7,5 Nm)
- Wire Rope Material: Stranded 300 series stainless steel
- Operating Temperature Range: -150°F to 500°F (-100°C to 260°C)
- U.S. Patent 6,244,579

Static Load vs. Deflection

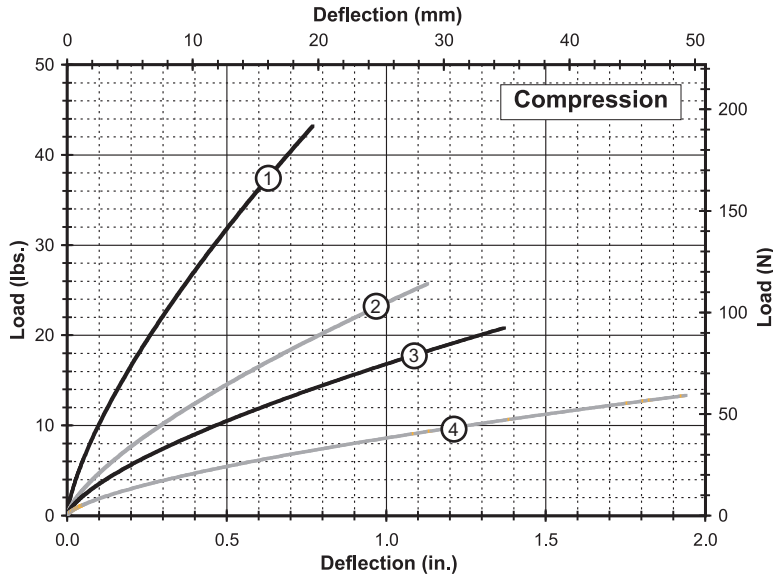

Compression

| Curve | Model | Max Static Load Lbs. (N) | Max Deflection in. (mm) | Kv (vibration) Lbs./in. (kN/m) | Ks (shock) Lbs./in. (kN/m) |
|-------|---------|--------------------------|-------------------------|--------------------------------|----------------------------|
| 1 | CR5-100 | 18 (80) | 0.77 (19,6) | 125 (22) | 65 (11) |
| 2 | CR5-200 | 8.5 (38) | 1.13 (28,7) | 60 (11) | 25 (4,4) |
| 3 | CR5-300 | 6.0 (27) | 1.37 (34,8) | 45 (7,9) | 18 (3,2) |
| 4 | CR5-400 | 3.5 (16) | 1.94 (49,3) | 25 (4,4) | 8 (1,4) |

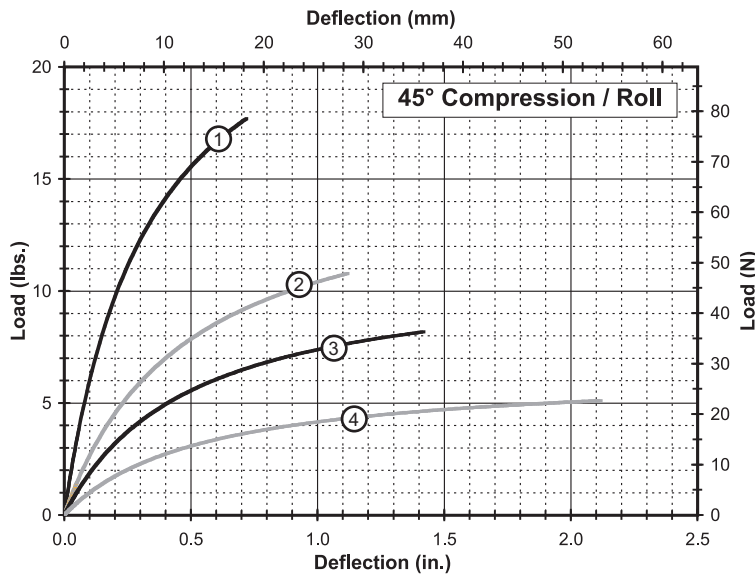

45° Compression/Roll

| Curve | Model | Max Static Load Lbs. (N) | Max Deflection in. (mm) | Kv (vibration) Lbs./in. (kN/m) | Ks (shock) Lbs./in. (kN/m) |
|-------|---------|--------------------------|-------------------------|--------------------------------|----------------------------|
| 1 | CR5-100 | 5.5 (24) | 0.72 (18,3) | 70 (12) | 35 (6,1) |
| 2 | CR5-200 | 3.0 (13) | 1.12 (28,4) | 30 (5,3) | 13 (2,3) |
| 3 | CR5-300 | 2.5 (11) | 1.42 (36,1) | 20 (3,6) | 8 (1,4) |
| 4 | CR5-400 | 1.5 (6,7) | 2.12 (53,8) | 11 (1,9) | 4 (0,70) |

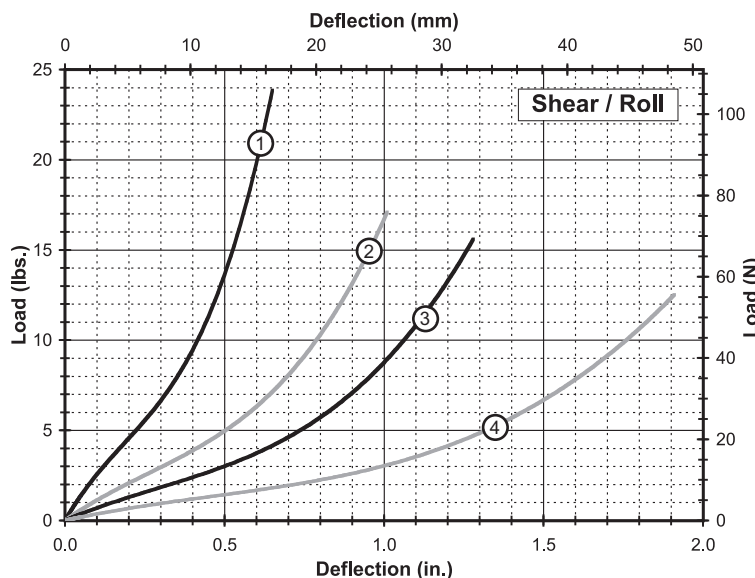

Shear/Roll

| Curve | Model | Max Static Load Lbs. (N) | Max Deflection in. (mm) | Kv (vibration) Lbs./in. (kN/m) | Ks (shock) Lbs./in. (kN/m) |
|-------|---------|--------------------------|-------------------------|--------------------------------|----------------------------|
| 1 | CR5-100 | 4.5 (20) | 0.65 (16,5) | 25 (4,4) | 25 (4,4) |
| 2 | CR5-200 | 3.0 (13) | 1.01 (25,7) | 12 (2,1) | 12 (2,1) |
| 3 | CR5-300 | 2.5 (11) | 1.28 (32,5) | 8 (1,4) | 8 (1,4) |
| 4 | CR5-400 | 1.5 (6,7) | 1.91 (48,5) | 4 (0,70) | 4 (0,70) |

Note: Do not extrapolate plotted curves.

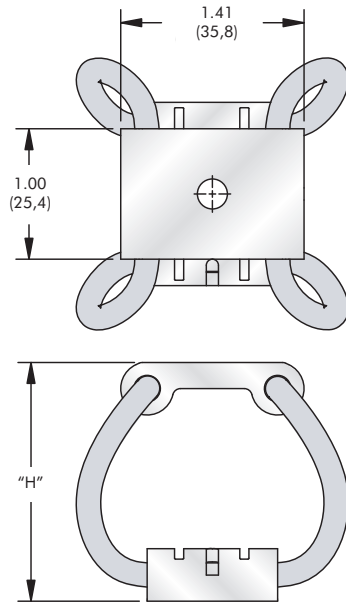

Note: Dimensions are in inches (mm)
Tolerances are ± .010 (± .25mm)

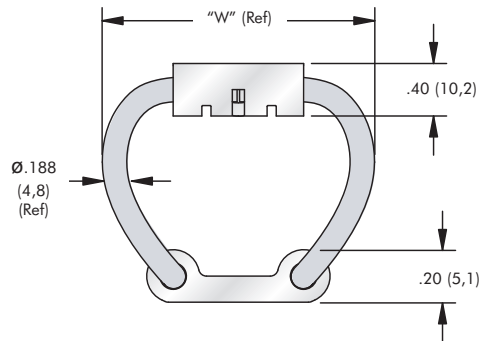

| Size | Height "H" in. (mm) | Width (Ref) "W" in. (mm) | Unit Weight oz. (g) | Mounting Options | Thru Hole in. (mm) | Thread in. (mm) | C'sink Imperial (Metric) |
|---------|---------------------|--------------------------|---------------------|------------------|--------------------|-----------------------|--------------------------|
| CR6-100 | 1.83 (47) | 2.11 (54) | 2.0 (57) | A, B, C, D, E, S | Ø.230 (Ø7,00) | #10-32 UNF (M6 X 1,0) | 82° (90°) |
| CR6-200 | 2.15 (55) | 2.31 (59) | 2.2 (62) | | | | |
| CR6-300 | 2.51 (64) | 2.50 (64) | 2.3 (65) | | | | |
| CR6-400 | 3.09 (79) | 2.86 (73) | 2.6 (74) | | | | |

Model Number Ordering Code

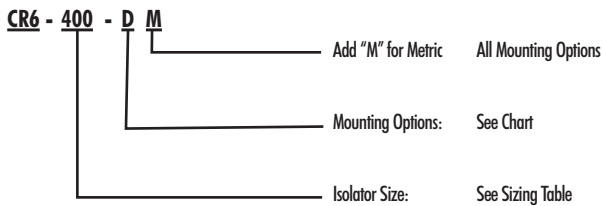

Mounting Options

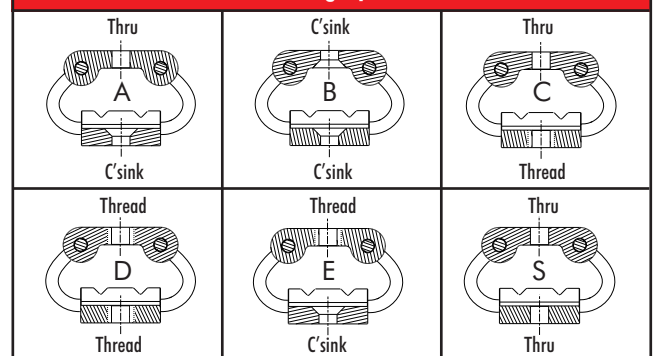

Wire Rope Special Options

Optional materials for the wire rope and mount bars are available upon request. Possibilities include galvanized rope, bell mouth mount bars or stainless steel rope and mount bars. Please contact Enidine to discuss in more detail. Minimum purchase quantities may apply. See page 37.

- Maximum recommended torque for tapped aluminum bar is 40 in.-lbs. (7,5 Nm)
- Wire Rope Material: Stranded 300 series stainless steel
- Operating Temperature Range: -150°F to 500°F (-100°C to 260°C)
- U.S. Patent 6,244,579

Static Load vs. Deflection

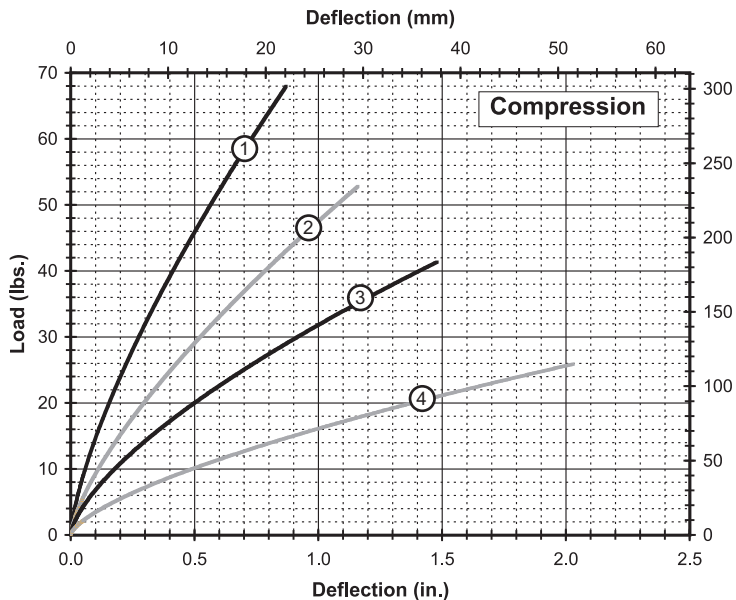

Compression

| Curve | Model | Max Static Load Lbs. (N) | Max Deflection in. (mm) | Kv (vibration) Lbs./in. (kN/m) | Ks (shock) Lbs./in. (kN/m) |
|-------|---------|--------------------------|-------------------------|--------------------------------|----------------------------|
| 1 | CR6-100 | 32 (142) | 0.87 (22,1) | 180 (32) | 90 (16) |
| 2 | CR6-200 | 21 (93) | 1.16 (29,5) | 115 (20) | 55 (9,6) |
| 3 | CR6-300 | 15 (67) | 1.48 (37,6) | 85 (15) | 30 (5,3) |
| 4 | CR6-400 | 8.0 (36) | 2.03 (51,6) | 45 (7,9) | 15 (2,6) |

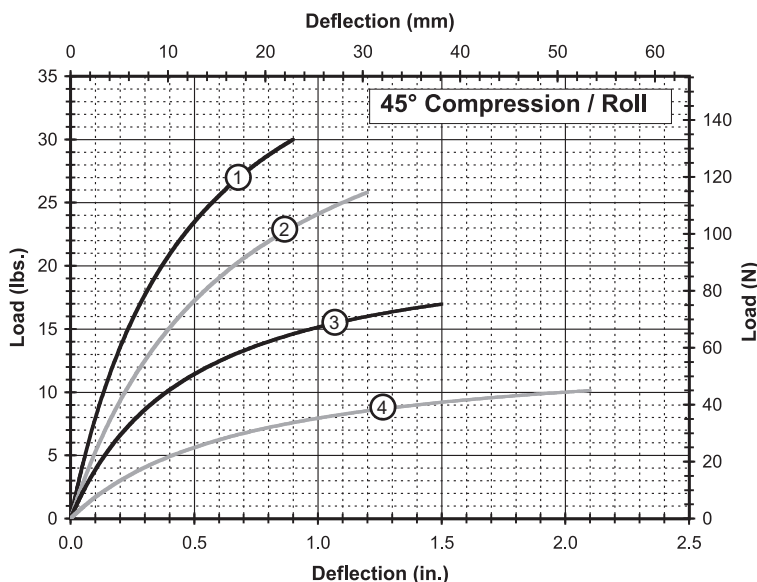

45° Compression/Roll

| Curve | Model | Max Static Load Lbs. (N) | Max Deflection in. (mm) | Kv (vibration) Lbs./in. (kN/m) | Ks (shock) Lbs./in. (kN/m) |
|-------|---------|--------------------------|-------------------------|--------------------------------|----------------------------|
| 1 | CR6-100 | 9.0 (40) | 0.9 (22,9) | 90 (16) | 45 (7,9) |
| 2 | CR6-200 | 7.5 (33) | 1.2 (30,5) | 55 (9,6) | 30 (5,3) |
| 3 | CR6-300 | 5.0 (22) | 1.5 (38,1) | 45 (7,9) | 16 (2,8) |
| 4 | CR6-400 | 3.0 (13) | 2.1 (53,3) | 20 (3,5) | 7 (1,2) |

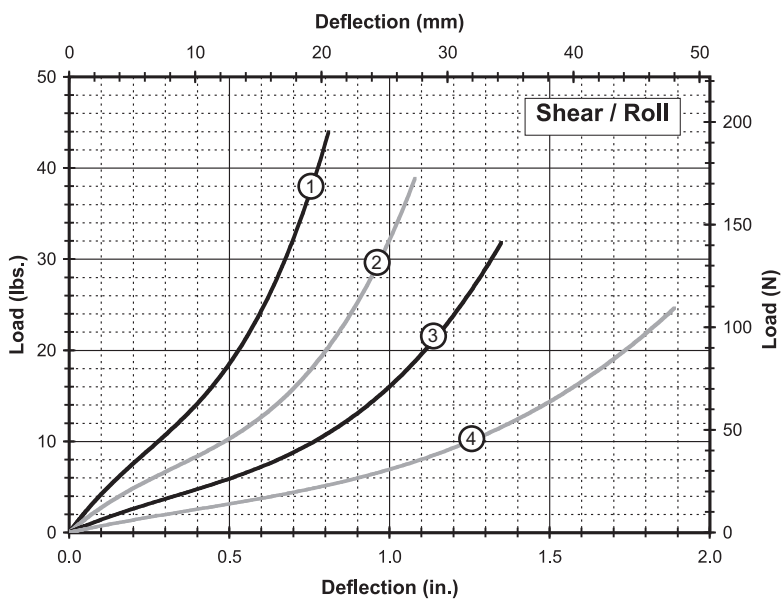

Shear/Roll

| Curve | Model | Max Static Load Lbs. (N) | Max Deflection in. (mm) | Kv (vibration) Lbs./in. (kN/m) | Ks (shock) Lbs./in. (kN/m) |
|-------|---------|--------------------------|-------------------------|--------------------------------|----------------------------|
| 1 | CR6-100 | 9.0 (40) | 0.81 (20,6) | 45 (7,9) | 45 (7,9) |
| 2 | CR6-200 | 7.0 (31) | 1.08 (27,4) | 25 (4,4) | 25 (4,4) |
| 3 | CR6-300 | 5.0 (22) | 1.35 (34,3) | 15 (2,6) | 15 (2,6) |
| 4 | CR6-400 | 3.5 (16) | 1.89 (48,0) | 9 (1,6) | 9 (1,6) |

Note: Do not extrapolate plotted curves.