



HI Series

ITT Enidine's **Heavy Industry (HI) Series** buffers safely protect heavy machinery and equipment during the transfer of materials and movement of products. The large-bore, high-capacity buffers are individually designed to decelerate moving loads under various conditions and in compliance with industry mandated safety standards. Control of bridge cranes, trolley platforms, large container transfer and transportation safety stops are typical installation examples. Industry-proven design technologies, coupled with the experience of a globally installed product base, ensure deliverable performance that exceeds customer expectations.

Prior to HI Series buffer manufacture, computer-simulated response curves are generated to model actual conditions, verify product performance, confirm damping characteristics and generate unique custom-orificed designs that accommodate multi-condition or specific damping requirements.

Characteristics of the HI Series include a nitrogen-charged return system that allows for soft deceleration and positive return in a maintenance-free package. The oversize bore area results in optimal energy absorption capabilities and increased internal safety factors. State-of-the-art testing facilities ensure integrity of design and product performance.

Features and Benefits

- Compact design smoothly and safely decelerates large energy capacity loads up to 500 kNm per cycle with standard stroke lengths.
- Engineered to meet OSHA, AISE, CMMA and other safety specifications such as DIN and FEM.
- Nitrogen-charged return system allows for soft deceleration and positive return in a maintenance-free package.
- Wide variety of optional configurations including protective bellows and safety cables.
- Available in custom-orificed non-adjustable models.
- Special epoxy painting and rod materials are available for use in highly corrosive environments.
- Surface treatment (Sea water resistant)
Housing: gray color, three-part epoxy
Piston Rod: hard-chrome plated steel.
- Incorporating optional fluids and seal packages available to expand standard operating temperature range from (-10°C to 60°C) and (-35°C to 100°C).

ITT Enidine Heavy Industry (HI) Series Buffers

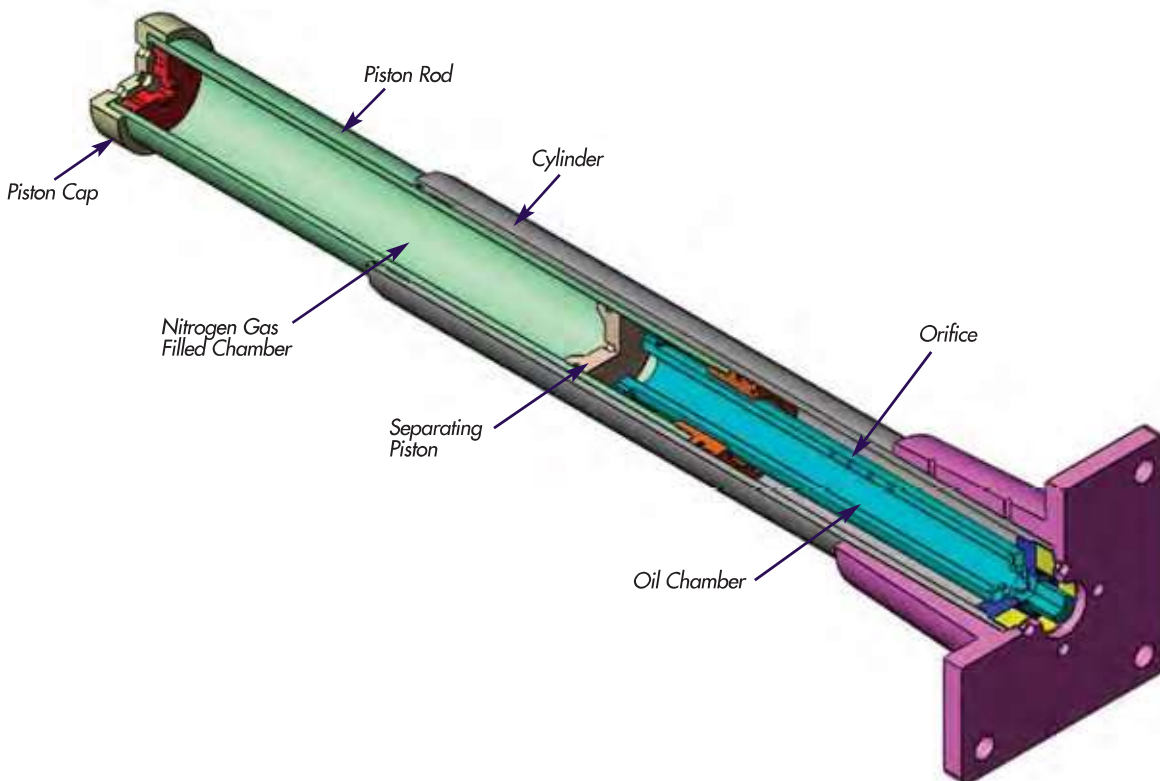

The **Heavy Industry (HI) Series** buffer design incorporates the proven damping system of multiple orifice patterns drilled down the shock tube length, for precise deceleration profiles, coupled with a nitrogen return system for controlled extension of the piston rod to its original position.

During piston movement, oil is forced through the orifice pattern into the oil reservoir chamber. This controlled movement of a piston head by decreasing the orifice area results in precise decay of impact velocity and safe deceleration of the moving load. The oil volume evacuated from the high pressure chamber moves the separating piston, compensating for the oil differential within the unit.

Extension of the piston rod for the next impact is accomplished by the force created from the compressed nitrogen chamber, which acts as both a oil volume compensator, and return force mechanism. The pressure created pushes the fluid back into the oil chamber and creates a force to reposition the piston rod to the fully extended position, ready for the next impact sequence. The nitrogen return system enables the HI Series to be designed for the maximum energy absorption within the smallest envelope size.

Ordering Example

Mounting Bracket flange:
Standard: Rear or Front mount

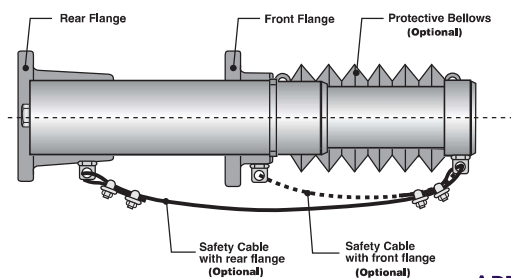

Example:

4

Select quantity

HI 120 x 100

Select HI Series model from Engineering Data Chart

FR

Select mounting method
• FF (Flange Front)
• FR (Flange Rear)

B

Additional Options
• B Protective bellows
• C Safety cable

APPLICATION DATA

- Required for all models:
- Vertical/Horizontal Motion
 - Mass
 - Impact Velocity
 - Propelling Force (if any)
 - Cycles/Hour
 - Temperature/Environment
 - Applicable Standards

HI 50 x 50 → HI 120 x 1000 Series

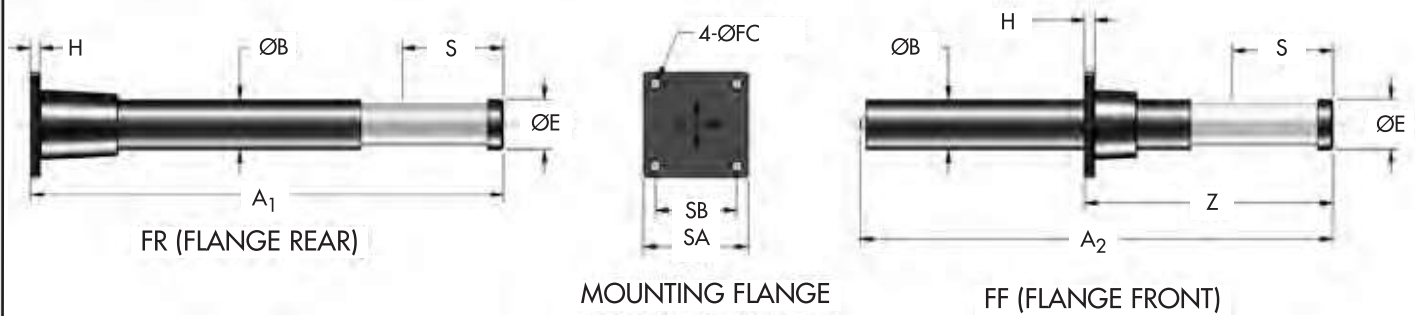

Catalog No./ Model	(S) Stroke mm	Max. Energy/cycle Nm/c	Max. Reaction Force kN	Return Force		Mass Kg	A ₁ mm	A ₂ mm	Z mm	H mm	ØB mm	SA mm	SB mm	ØFC mm	BOLT SIZE mm	ØE mm
				Extension kN	Compression kN											
HI 50 x 50	50	3 000	70	0,5	3,2	5	262	–	–	15	65	100	70	14,5	M14	58
HI 50 x 100	100	6 200	70	0,3	6,6	9	392	–	–	15	65	100	70	14,5	M14	58
HI 85 x 50	50	6 800	160	1,0	3,6	16	324	–	–	15	85	128	89	20	M18	79
HI 85 x 100	100	13 600	160	1,0	7,6	22	424	–	–	15	85	128	89	20	M18	79
HI 100 x 50	50	10 000	235	1,7	17,0	16	302	301	175	20	100	150	120	18,5	M16	99
HI 100 x 100	100	20 000	235	1,7	18,0	22	479	473	245	20	100	150	120	18,5	M16	99
HI 100 x 150	150	30 000	235	1,7	16,6	28	618	612	300	20	100	150	120	18,5	M16	99
HI 100 x 200	400	80 000	235	1,7	16,6	46	1 349	1 345	645	20	100	150	120	18,5	M16	99
HI 100 x 400	400	80 000	235	1,7	17,5	46	1 349	1 345	645	20	100	150	120	18,5	M16	99
HI 100 x 500	500	94 000	235	1,7	24,2	52	–	1 616	890	20	100	150	120	18,5	M16	99
HI 100 x 600	600	112 000	220	1,7	24,2	58	–	1 888	1 040	20	100	150	120	18,5	M16	99
HI 100 x 800	800	136 000	200	1,7	24,2	69	–	2 426	1 345	20	100	150	120	18,5	M16	99
HI 120 x 100	100	32 000	375	2,7	34,5	34	471	467	270	20	120	220	170	26,5	M24	127
HI 120 x 150	150	48 000	375	2,7	34,5	39	597	593	330	20	120	220	170	26,5	M24	127
HI 120 x 200	200	64 000	375	2,7	34,5	43	724	720	390	20	120	220	170	26,5	M24	127
HI 120 x 300	300	94 000	375	2,7	38,0	53	973	969	520	20	120	220	170	26,5	M24	127
HI 120 x 400	400	125 000	375	2,7	38,0	87	1 225	1 221	680	25	120	220	170	26,5	M24	127
HI 120 x 600	600	188 000	375	2,7	42,8	105	–	1 725	915	25	120	220	170	26,5	M24	127
HI 120 x 800	800	225 000	330	2,7	37,4	110	–	2 332	1 290	25	120	220	170	26,5	M24	127
HI 120 x 1000	1000	260 000	300	2,7	37,4	116	–	2 836	1 360	25	120	220	170	26,5	M24	127

Heavy Industry Shock Absorbers

HI Series

HI 130 x 250 → HI 150 x 1000 Series

Technical Data

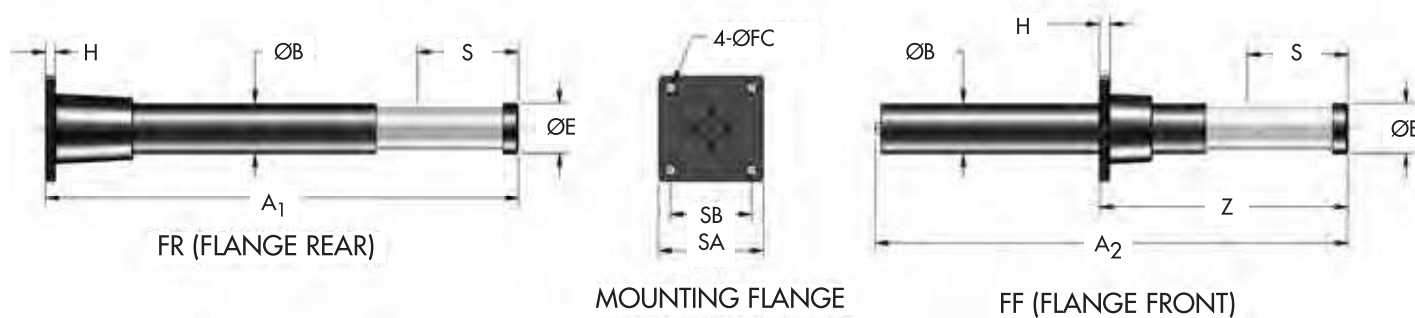

Catalog No./ Model	S Stroke mm	Max. Energy/cycle Nm/c	Max. Reaction Force kN	Return Force		Mass Kg	A ₁ mm	A ₂ mm	Z mm	H mm	ØB mm	SA mm	SB mm	ØFC mm	BOLT SIZE mm	ØE mm
				Extension kN	Compression kN											
HI 130 x 250	250	100 000	475	3,2	50,0	72	897	894	545	25	130	270	210	26,5	M24	129
HI 130 x 300	250	100 000	475	3,2	50,0	72	897	894	545	25	130	270	210	26,5	M24	129
HI 130 x 400	400	160 000	475	3,2	50,0	90	1 293	1 289	735	25	130	270	210	26,5	M24	129
HI 130 x 600	600	210 000	400	3,2	45,0	119	–	1 917	1 055	25	130	270	210	26,5	M24	129
HI 130 x 800	800	270 000	400	3,2	45,0	140	–	2 445	1 345	25	130	270	210	26,5	M24	129
HI 150 x 115	115	62 000	645	4,5	65,7	56	516	513	320	25	150	270	210	26,5	M24	149
HI 150 x 150	150	82 000	645	4,5	65,7	59	606	602	355	25	150	270	210	26,5	M24	149
HI 150 x 400	400	220 000	645	4,5	62,4	98	1 257	1 247	710	25	150	270	210	26,5	M24	149
HI 150 x 500	500	275 000	645	4,5	75,5	110	–	1 500	770	25	150	270	210	26,5	M24	149
HI 150 x 600	600	330 000	645	4,5	75,5	120	–	1 754	875	25	150	270	210	26,5	M24	149
HI 150 x 800	800	435 500	640	4,5	68,0	165	–	2 365	1 240	25	150	270	210	26,5	M24	149
HI 150 x 1000	1000	510 000	600	4,5	61,0	180	–	2 887	1 595	25	150	270	210	26,5	M24	149